



# Stainless Steel Pneumatic Cylinders

## Stainless Steel Body Air Cylinders



American Cylinder Co., Inc.

**Stainless Steel Series**

**Standard Catalog**

**5/16 inch through**

**3 inch bore**

# TABLE OF CONTENTS

Table of Contents .....	Page 1	<b>Double Acting Models</b>	
<b>Standard Model Selection</b> .....	Page 1	Mounting: Nose Mount .....	Page 13
<b>Standard Features and Benefits</b> .....	Page 2	Universal Mount.....	Page 14
<b>How to Order</b> .....	Page 3	<b>Double Acting Models</b>	
<b>Lubrication</b> .....	Page 4	Mounting: Block Front &	
<b>Temperature Ratings</b> .....	Page 4	Block Front Trunnion Mount .....	Page 15
<b>Non-Standard Stroke Lengths</b> .....	Page 4	Block Rear &	
<b>Standard Stroke Lengths</b> .....	Page 5 & 6	Block Rear Trunnion Mount.....	Page 16
<b>Single Acting Models</b>		Double End Rod .....	Page 17
Mounting: Nose Mount .....	Page 7	Double End Hollow Rod .....	Page 17
Universal Mount .....	Page 8	<b>Volume Chambers</b> .....	Page 18
<b>Single Acting Non-Rotating Models</b>		<b>Reverse Acting Models</b>	
Mounting: Nose Mount .....	Page 9	Mounting: Nose Mount .....	Page 19
Universal Mount .....	Page 10	Universal Mount.....	Page 20
<b>Single Acting Models</b>		Block Front &	
Mounting: Block Front &		Block Front Trunnion Mount .....	Page 21
Block Front Trunnion Mount .....	Page 11	Block Rear &	
Block Rear &		Block Rear Trunnion Mount.....	Page 22
Block Rear Trunnion Mount .....	Page 12	<b>Mounting Accessories</b>	
		Dimensional Data .....	Page 23 & 24
		<b>Warranty</b> .....	Page 25

# STANDARD MODEL SELECTION

			Available Bore Sizes										
	Model	Description	5/16	7/16	9/16	3/4	7/8	1 1/16	1 1/4	1 1/2	1 3/4	2	3
S I N G L E	SNS	Single Acting Nose Mount	•	•	•	•	•	•	•	•	•	•	
	SVS	Single Acting Universal Mount	•	•	•	•	•	•	•	•	•	•	
	SNHS	Single Acting Non-Rotating Nose Mount	•	•	•	•	•	•	•				
	SVHS	Single Acting Non-Rotating Universal Mount	•	•	•	•	•	•	•				
	SBFS	Single Acting Block Front Mount		•		•		•		•			
	SBFTS	Single Acting Block Front Trunnion Mount		•		•		•		•			
	SBRS	Single Acting Block Rear Mount		•		•		•		•			
	SBRTS	Single Acting Block Rear Trunnion Mount		•		•		•		•			
D O U B L E	DNS	Double Acting Nose Mount	•	•	•	•	•	•	•	•	•	•	•
	DVS	Double Acting Universal Mount	•	•	•	•	•	•	•	•	•	•	•
	DBFS	Double Acting Block Front Mount	•	•	•	•		•		•			
	DBFTS	Double Acting Block Front Trunnion Mount		•		•		•		•			
	DBRS	Double Acting Block Rear Mount		•		•		•		•			
	DBRTS	Double Acting Block Rear Trunnion Mount		•		•		•		•			
	DES	Double End Rod		•	•	•	•	•	•	•	•	•	•
	DEHS	Double End Hollow Rod				•		•	•	•			
R E C T I N G	RNS	Reverse Acting Nose Mount	•	•	•	•	•	•	•	•	•	•	
	RVS	Reverse Acting Universal Mount	•	•	•	•	•	•	•	•	•	•	
	RBFS	Reverse Acting Block Front Mount		•		•		•		•			
	RBFTS	Reverse Acting Block Front Trunnion Mount		•		•		•		•			
	RBRS	Reverse Acting Block Rear Mount		•		•		•		•			
	RBRTS	Reverse Acting Block Rear Trunnion Mount		•		•		•		•			
	VCS	Volume Chamber	•	•	•	•	•	•	•	•	•	•	•

## STANDARD FEATURES AND BENEFITS

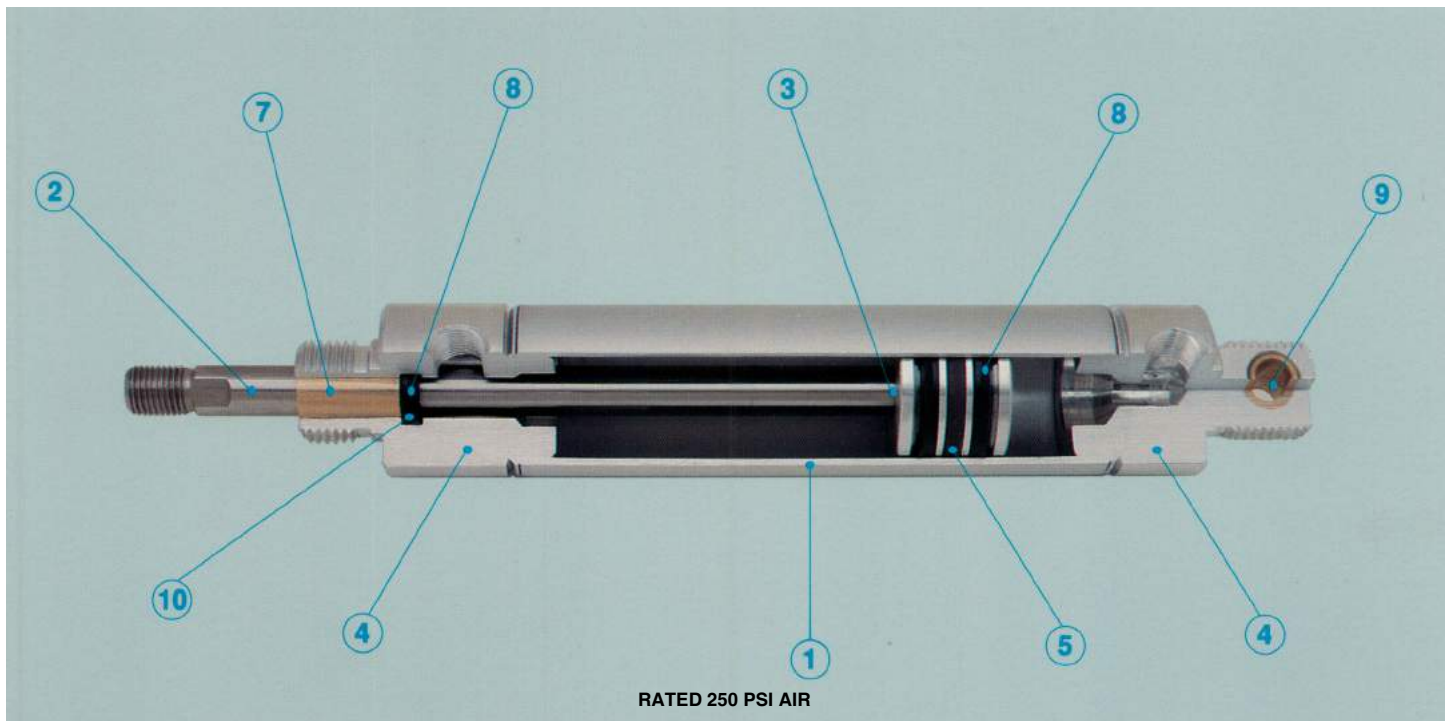

① **Stainless Steel Cylinder Body:** Type 304 Stainless Steel manufactured to special mill specifications and tolerances to insure a long cylinder life.

② **Stainless Steel Rod:** Ground & Polished Type 303 Stainless Steel rods are standard on the Stainless Steel Series. All rods 1/4" diameter and larger have wrench flats and stress relief grooves.

③ **Piston Rod Assembly:** Piston rods are threaded, anaerobically sealed, and machine staked into the piston for triple protection.

④ **End Caps, Piston:** High strength aluminum alloy.

⑤ **Magnet for Sensing Switch Actuation:** Optional, refer to American Cylinder's MFC® catalog for details.

⑥ **Springs:** Springs for spring action cylinders are made from music wire and designed for millions of cycles. Special spring forces are available.

⑦ **Rod Guide Bushing:** Standard on all models. The oil impregnated sintered bronze bushing increases the life of the cylinder rod and provides a non-abrasive bearing surface.

⑧ **Buna-N U-Cup Rod & Piston Seals:** U-Cup seals provide low breakaway friction and maximize cylinder life expectancy. Standard Buna-N seals are recommended for operating temperatures of -20° F (-25°C) to 200° F (95°C). Fluoroelastomer seals are available for higher temperature applications.

⑨ **Pivot Pin/Pivot Bushing:** Stainless Steel Series cylinders are shipped with plated steel pivot pins as standard. Sintered bronze pivot bushings are available as an alternative standard option. (5/16", 13/4", 2" & 3" bores supplied with pivot bushing only.)

⑩ **Rod Seal:** Precision machined rod seal groove provides a smooth sealing surface while positively retaining the seal without requiring additional components and relying on press fit containment.

⑪ **Prelubricated:** All cylinders are factory lubricated with a special high endurance oil mixture.

⑫ **Pre-Tested:** The quality of each cylinder is assured by testing each unit for leakage prior to shipment. Quality control provides added value to American cylinders.

Product enhancements resulting from our quality improvement program may necessitate changes in specifications without notice.



# HOW TO ORDER:

**Example:** 1 1/16" Bore Double Acting Universal Mount Cylinder  
2" Stroke - Bumpers - Ports Rotated 90°

**Model No.:** 1062DVS-2.00-32-33

**Model No. Composition:** 1062 DVS - 2.00 - 32 - 33

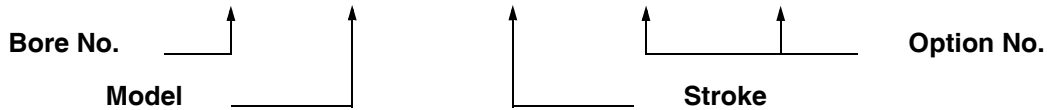

Bore	No.	Model Description	Model	Standard Options	No.
5/16"	312	Single Acting Nose Mount	SNS	1/8" Additional Rod Extension	1 <sup>a</sup>
7/16"	437	Single Acting Universal Mount	SVS	Rear Pivot Bushing (Omit Pin)	2
9/16"	562	Single Acting Non-Rotating Nose Mount	SNHS	Unmilled, Threaded Rear Mtg. Stud	3 <sup>b</sup>
3/4"	750	Single Acting Non-Rotating Universal Mount	SVHS	Magnetic Field Piston	4 <sup>c</sup>
7/8"	875	Single Acting Block Front Mount	SBFS	Quad-X Wiper/Seal in Front Head	5 <sup>d</sup>
1 1/16"	1062	Single Acting Block Front Trunnion Mount	SBFTS	Magnalube <sup>®</sup> Lubrication	6
1 1/4"	1250	Single Acting Block Rear Mount	SBRS	No Rod Thds. or Flats, Std. Overall Ext.	9
1 1/2"	1500	Single Acting Block Rear Trunnion Mount	SBRTS	Fluoroelastomer Seals	31
1 3/4"	1750	Double Acting Nose Mount	DNS	Bumpers	32 <sup>e</sup>
2"	2000	Double Acting Universal Mount	DVS	Ports Rotated 90°	33
3"	3000	Double Acting Block Front Mount	DBFS	Side Port Rear Cap	38 <sup>f</sup>
		Double Acting Block Front Trunnion Mount	DBFTS	Quad-X Seal in Front Piston	51 <sup>g</sup>
		Double Acting Block Rear Mount	DBRS	"UNC" Coarse Rod Threads	91 <sup>h</sup>
		Double Acting Block Rear Trunnion Mount	DBRTS		
		Double End Rod	DES		
		Double End Hollow Rod	DEHS		
		Reverse Acting Nose Mount	RNS		
		Reverse Acting Universal Mount	RVS		
		Reverse Acting Block Front Mount	RBFS		
		Reverse Acting Block Front Trunnion Mount	RBFTS		
		Reverse Acting Block Rear Mount	RBRS		
		Reverse Acting Block Rear Trunnion Mount	RBRTS		
		Volume Chamber	VCS		

NOTES

- a 1 1/16" bore only.
- b Reduces tang length by .250 on the 1 1/2" bore models. Same thread as nose thread.
- c Consult American's MFC<sup>®</sup> catalog for product information.
- d In addition to Standard U-Cup Rod Seal. Not available in Block models or 5/16", 7/16" or 9/16" bore sizes.
- e See pages 5 & 6 for Bumper Length Adder.
- f Available on Nose mounted models excluding Reverse Acting Nose Mount models. See page 5 for Length Adders.
- g Not available in 5/16", 7/16" or 9/16" bore sizes. Also, not available on any Single or Reverse Acting model.
- h Same thread length, extension and rod flats as standard models. Not available in 5/16", 7/16" or 9/16" bore sizes.

**(-91) "UNC" Coarse Rod Threads "P" Dimension.**

Bore	3/4" & 7/8"	1 1/16"	1 1/4" & 1 1/2"	1 3/4"	2"	3"
"P" Dim.	1/4-20	5/16-18	7/16-14	1/2-13	1/2-13	5/8-11

Product enhancements resulting from our quality improvement program may necessitate changes in specifications without notice.

American Cylinder Distributors are located in every major industrial market.

## LUBRICATION

American cylinders are prelubricated at the factory prior to shipment to provide millions of trouble free cycles. Most applications do not require additional lubrication, however, cylinder life can be maximized through periodic direct lubrication or continuous air line mist lubrication. Atlantic Richfield Duro S-315 oil is recommended for cylinders having standard Buna-N seals. Dow Corning Molykote 710G is recommended for cylinders with high temperature Fluoroelastomer seals. Consult your American Cylinder distributor or the factory for special lubrication requirements.

## TEMPERATURE RATINGS

Buna-N seals are supplied as standard in all American Cylinder models and are recommended for operating temperatures in the -20° F (-25°C) to 200° F (95°C) range. Fluoroelastomer seals are recommended for high temperature cylinder applications having operating temperatures up to 400°F (204°C).

## NON-STANDARD STROKE LENGTHS

American Cylinder's Specials Department will produce cylinders with non-standard and fractional stroke lengths. Consult your local distributor for non-standard stroke cylinder pricing. Fractional stroke cylinder lengths can be determined as illustrated by the following examples:

### Single Acting Cylinders

Calculate the length of the next longer whole inch increment of stroke and subtract the difference between desired stroke and the next longer whole inch increment of stroke.

**Example:** 1062SVS-1.75

**Step 1:** Calculate length for next largest whole inch increment.

1062SVS Base Length, Dim.A	=	2.81"
Plus: (Dim.B) x Stroke Increment		
1.56 x 2.00	=	3.12"
Length of 2" Stroke	=	5.93"

**Step 2:** Subtract desired stroke from stroke increment used above.

Whole inch stroke used in Step 1	=	2.00"
Less: 1.75" Desired stroke	=	1.75"
Stroke difference	=	0.25"

**Step 3:** Subtract stroke difference from length calculated in Step 1.

Length of 1062SVS-2.00, (Step 1)	=	5.93"
Less: Stroke difference, (Step 2)	=	0.25"
Length of 1062SVS-1.75	=	5.68"

### Double Acting Cylinders

Add desired stroke length to base length of the cylinder.

**Example:** 1062DNS-2.75

1062DNS Base Length, Dim.A	=	3.12"
Plus stroke length	=	2.75"
Length of 1062DNS-2.75	=	5.87"

### Reverse Acting Cylinders

Calculate the length of the next longer whole inch increment of stroke and subtract twice the difference between the desired stroke and the next longer whole inch increment of stroke.

**Example:** 1500RVS-1.25

**Step 1:** Calculate length for next largest whole inch increment.

1500RVS Base Length, Dim.A	=	4.25"
Plus: (Dim.B) x Stroke Increment		
3.00 x 2.00	=	6.00"
Length of 2" Stroke	=	10.25"

**Step 2:** Calculate twice the difference between the desired stroke length and the whole inch stroke increment used in Step 1.

Whole inch stroke used in Step 1	=	2.00"
Less: 1.25" Desired stroke	=	1.25"
Stroke difference	=	0.75"
Multiply by 2	x	2
Twice the stroke difference	=	1.50"

**Step 3:** Subtract value calculated in Step 2 from value obtained in Step 1.

Length of 1500RVS-2.00, (Step 1)	=	10.25"
Less: Stroke factor, (Step 2)	=	1.50"
Length of 1500RVS-1.25	=	8.75"

NOTES

- For 5/16" & 7/16" bore spring models, calculate to next largest 1/2" stroke increment.
- Standard stroke lengths are listed on pages 5 & 6.

# STANDARD STROKE LENGTHS

## Single Acting

Models SNS & SVS - Pages 7 & 8  
Models SNHS & SVHS - Pages 9 & 10

Bore	Standard Stroke Lengths (in.)	Spring Forces		Bumper (-32) Length Adder	Side Port (-38) Length Adder	Power Factor
		Rod Ret.	Rod Ext.			
5/16"	1/2, 1, 1 1/2, 2, 3, 4	0.5	1.0	.00	.21	.07
7/16"	1/2, 1, 1 1/2, 2, 3, 4	1.0	2.0	.06	.18	.15
9/16"	1/2, 1, 1 1/2, 2, 3, 4	2.0	4.0	.06	.09	.25
3/4"	1/2, 1, 1 1/2, 2, 3, 4	3.0	6.0	.12	.43	.44
7/8"	1/2, 1, 1 1/2, 2, 3, 4	3.0	6.0	.00	.28	.60
1 1/16"	1/2, 1, 1 1/2, 2, 3, 4	3.0	6.0	.12	.25	.89
1 1/4"	1/2, 1, 1 1/2, 2, 3, 4	7.5	15.0	.00	.31	1.23
1 1/2"	1/2, 1, 1 1/2, 2, 3, 4	6.0	12.0	.12	.18	1.77
1 3/4"*	1/2, 1, 1 1/2, 2, 3, 4	12.0	24.0	.00	.56	2.40
2" *	1/2, 1, 1 1/2, 2, 3, 4	15.0	30.0	.00	.37	3.14

\* SNHS & SVHS not available in 1 3/4" or 2" bore.

Models SBFS & SBFTS - Page 11  
Models SBRS & SBRTS - Page 12

Bore	Standard Stroke Lengths (in.)	Spring Forces		Bumper (-32) Length Adder	Side Port (-38) Length Adder	Power Factor
		Rod Ret.	Rod Ext.			
7/16"	1/2, 1, 1 1/2, 2, 3, 4	1.0	2.0	.06	.18	.15
3/4"	1/2, 1, 1 1/2, 2, 3, 4	3.0	6.0	.12	.43	.44
1 1/16"	1/2, 1, 1 1/2, 2, 3, 4	6.0	13.0	.12	.25	.89
1 1/2"	1/2, 1, 1 1/2, 2, 3, 4	8.5	17.0	.12	.18	1.77

## Double Acting

Models DNS & DVS - Pages 13 & 14  
Models VCS - Page 18

Bore	Standard Stroke Lengths (in.)	Bumper (-32) Length Adder	Side Port (-38) Length Adder	Power Factor	
				Push	Pull
5/16"	1/2, 1, 1 1/2, 2, 3, 4	.00	.21	.07	.06
7/16"	1/2, 1, 1 1/2, 2, 3, 4	.18	.18	.15	.12
9/16"	1/2, 1, 1 1/2, 2, 3, 4	.12	.09	.25	.22
3/4"	1/2, 1, 1 1/2, 2, 3, 4, 5, 6, 8, 10, 12	.00	.43	.44	.39
7/8"	1/2, 1, 1 1/2, 2, 3, 4, 5, 6, 8, 10, 12	.00	.28	.60	.55
1 1/16"	1/2, 1, 1 1/2, 2, 3, 4, 5, 6, 8, 10, 12	.12	.25	.89	.81
1 1/4"	1/2, 1, 1 1/2, 2, 3, 4, 5, 6, 8, 10, 12	.00	.31	1.23	1.07
1 1/2"	1/2, 1, 1 1/2, 2, 3, 4, 5, 6, 8, 10, 12, 14, 16, 18	.12	.18	1.77	1.62
1 3/4"	1/2, 1, 1 1/2, 2, 3, 4, 5, 6, 8, 10, 12, 14, 16, 18	.00	.56	2.40	2.20
2"	1/2, 1, 1 1/2, 2, 2 1/2, 3, 4, 5, 6, 7, 8, 9, 10, 11, 12, 14, 16, 18, 20, 22, 24	.25	.37	3.14	2.83
3"	1/2, 1, 1 1/2, 2, 2 1/2, 3, 4, 5, 6, 7, 8, 9, 10, 11, 12, 14, 16, 18, 20, 22, 24	.25	.37	7.06	6.62

NOTE: Stroke lengths in blue only apply to DVS & VCS models.

Models DBFS & DBFTS - Page 15  
Models DBRS & DBRTS - Page 16

Bore	Standard Stroke Lengths (in.)	Bumper (-32) Length Adder	Side Port (-38) Length Adder	Power Factor	
				Push	Pull
5/16"	1/2, 1, 1 1/2, 2, 3, 4	.00	.21	.07	.06
7/16"	1/2, 1, 1 1/2, 2, 3, 4	.18	.18	.15	.12
9/16"	1/2, 1, 1 1/2, 2, 3, 4	.12	.09	.25	.22
3/4"	1/2, 1, 1 1/2, 2, 3, 4, 5, 6	.00	.43	.44	.39
1 1/16"	1/2, 1, 1 1/2, 2, 3, 4, 5, 6	.12	.25	.89	.81
1 1/2"	1/2, 1, 1 1/2, 2, 3, 4, 5, 6	.12	.18	1.77	1.62

# STANDARD STROKE LENGTHS (Continued)

## Double Acting (Continued)

Model DES - Page 17

Bore	Standard Stroke Lengths (in.)	Bumper (-32)	Power Factor
		Length Adder	
7/16"	1/2, 1, 1 1/2, 2, 3, 4	.25	.12
9/16"	1/2, 1, 1 1/2, 2, 3, 4	.12	.22
3/4"	1/2, 1, 1 1/2, 2, 3, 4, 5, 6, 8, 10, 12	.00	.39
7/8"	1/2, 1, 1 1/2, 2, 3, 4, 5, 6, 8, 10, 12	.00	.55
1 1/16"	1/2, 1, 1 1/2, 2, 3, 4, 5, 6, 8, 10, 12	.50	.81
1 1/4"	1/2, 1, 1 1/2, 2, 3, 4, 5, 6, 8, 10, 12	.00	1.07
1 1/2"	1/2, 1, 1 1/2, 2, 3, 4, 5, 6, 8, 10, 12	.12	1.62
1 3/4"	1/2, 1, 1 1/2, 2, 3, 4, 5, 6, 8, 10, 12	.00	2.20
2"	1/2, 1, 1 1/2, 2, 2 1/2, 3, 4, 5, 6, 7, 8, 9, 10, 11, 12	.25	2.83
3"	1/2, 1, 1 1/2, 2, 2 1/2, 3, 4, 5, 6, 7, 8, 9, 10, 11, 12	.25	6.62

Models DEHS - Page 17

Bore	Standard Stroke Lengths (in.)	Bumper (-32)	Power Factor
		Length Adder	
3/4"	1/2, 1, 1 1/2, 2, 3, 4, 5, 6, 8, 10, 12	.00	.39
1 1/16"	1/2, 1, 1 1/2, 2, 3, 4, 5, 6, 8, 10, 12	.50	.81
1 1/4"	1/2, 1, 1 1/2, 2, 3, 4, 5, 6, 8, 10, 12	.00	1.07
1 1/2"	1/2, 1, 1 1/2, 2, 3, 4, 5, 6, 8, 10, 12	.12	1.62

## Reverse Acting

Models RNS & RVS - Pages 19 & 20

Bore	Standard Stroke Lengths (in.)	Spring Forces		Bumper (-32)	Power Factor
		Rod Ret.	Rod Ext.		
5/16"	1/2, 1, 1 1/2, 2, 3, 4	1.0	0.5	.00	.06
7/16"	1/2, 1, 1 1/2, 2, 3, 4	2.0	1.0	.12	.12
9/16"	1/2, 1, 1 1/2, 2, 3, 4	4.0	2.0	.06	.22
3/4"	1/2, 1, 1 1/2, 2, 3, 4	6.0	3.0	.12	.39
7/8"	1/2, 1, 1 1/2, 2, 3, 4	6.0	3.0	.00	.55
1 1/16"	1/2, 1, 1 1/2, 2, 3, 4	6.0	3.0	.12	.81
1 1/4"	1/2, 1, 1 1/2, 2, 3, 4	15.0	7.5	.00	1.07
1 1/2"	1/2, 1, 1 1/2, 2, 3, 4	12.0	6.0	.12	1.62
1 3/4"	1/2, 1, 1 1/2, 2, 3, 4	24.0	12.0	.00	2.20
2"	1/2, 1, 1 1/2, 2, 3, 4	30.0	15.0	.00	2.83

Models RBFS & RBFTS - Page 21  
Models RBRS & RBRTS - Page 22

Bore	Standard Stroke Lengths (in.)	Spring Forces		Bumper (-32)	Power Factor
		Rod Ret.	Rod Ext.		
7/16"	1/2, 1, 1 1/2, 2, 3, 4	2.0	1.0	.12	.22
3/4"	1/2, 1, 1 1/2, 2, 3, 4	6.0	3.0	.12	.39
1 1/16"	1/2, 1, 1 1/2, 2, 3, 4	13.0	6.0	.12	.81
1 1/2"	1/2, 1, 1 1/2, 2, 3, 4	17.0	8.5	.12	1.62

## SINGLE ACTING: Nose Mount

### Nose Mount

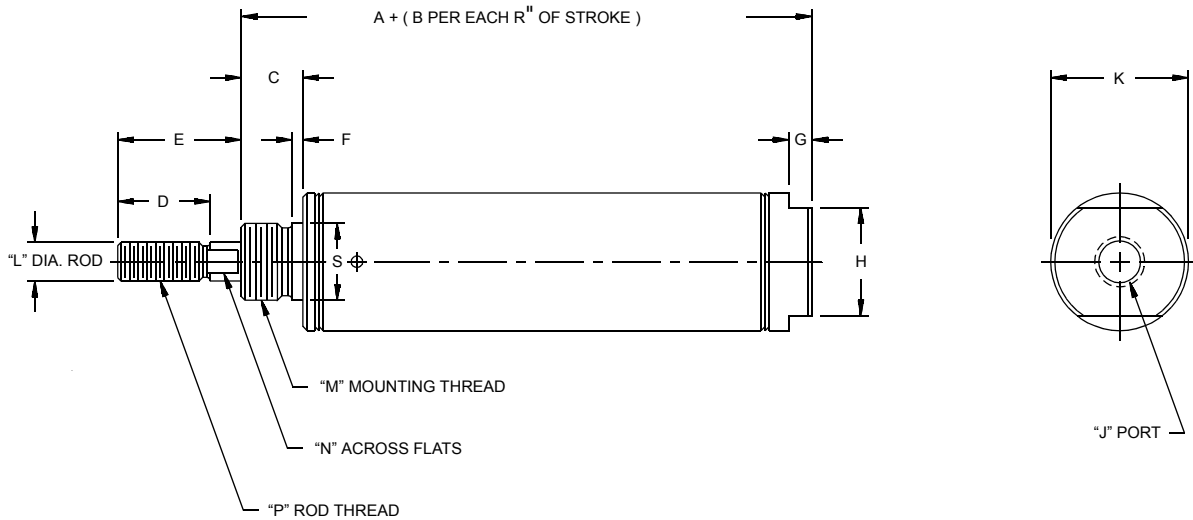

### 2" BORE LENGTHS

2" Bore	
Stroke	A + (B per R" of Stroke)
0.50	4.53
1.00	5.03

2" Bore	
Stroke	A + (B per R" of Stroke)
1.50	6.53
2.00	7.03

2" Bore	
Stroke	A + (B per R" of Stroke)
3.00	8.28
4.00	11.21

## Stainless Body Series - Model SNS - Single Acting Nose Mount

Bore	Dimension																Mounting Accessories		
	A	B	C	D	E	F	G	H	J	K	L	M	N	P	R	S	Foot Bkt.	Rod Clevis	Mtg. Nut
5/16"	1.12	0.75	.25	.37	0.37	.04	---	---	10-32	0.36	.12	1/4-28	---	5-40	0.50	0.25	M01SS	M04S	M05SS
7/16"	1.31	0.93	.31	.50	0.50	.05	.18	0.37	10-32	0.48	.18	3/8-24	---	10-32	0.50	0.37	M11SS	M14S	M15SS
9/16"	1.46	1.62	.37	.50	0.50	.05	.18	0.50	10-32	0.62	.18	7/16-20	---	10-32	1.00	0.43	M11SD	M14S	M15SD
3/4"	1.50	1.68	.43	.50	0.50	.05	.18	0.62	1/8 NPT	0.81	.25	1/2-20	.21	1/4-28	1.00	0.50	M21SS	M24S	M25SS
7/8"	1.84	1.56	.50	.50	0.50	.06	.18	0.62	1/8 NPT	0.93	.25	5/8-18	.21	1/4-28	1.00	0.62	M21	M24S	M25
1 1/16"	1.93	1.56	.50	.50	0.50*	.06	.18	0.87	1/8 NPT	1.12	.31	5/8-18	.25	5/16-24	1.00	0.62	M21	M24	M25
1 1/4"	2.40	1.81	.62	.75	1.00	.09	.18	0.87	1/8 NPT	1.34	.43	3/4-16	.37	7/16-20	1.00	0.75	M61S	M64S	M45
1 1/2"	2.18	1.68	.62	.75	1.00	.09	.25	0.87	1/8 NPT	1.56	.43	3/4-16	.37	7/16-20	1.00	0.75	M61S	M64S	M45
1 3/4"	2.65	2.00	.75	.87	1.18	.09	.25	1.25	1/4 NPT	1.84	.50	1-14	.43	1/2-20	1.00	1.03	M71S	M94	M65
2"	☆	☆	.81	.87	1.25	.10	.25	1.25	1/4 NPT	2.09	.62	1 1/4-12	.56	1/2-20	☆	1.37	M81S	M94	M85

NOTES

- \* Specify Option No. 1 to increase rod extension an additional 1/8"; thread length remains 0.50.
- ☆ See chart above for 2" bore length dimensions.



# SINGLE ACTING: Universal Mount

## Universal Mount

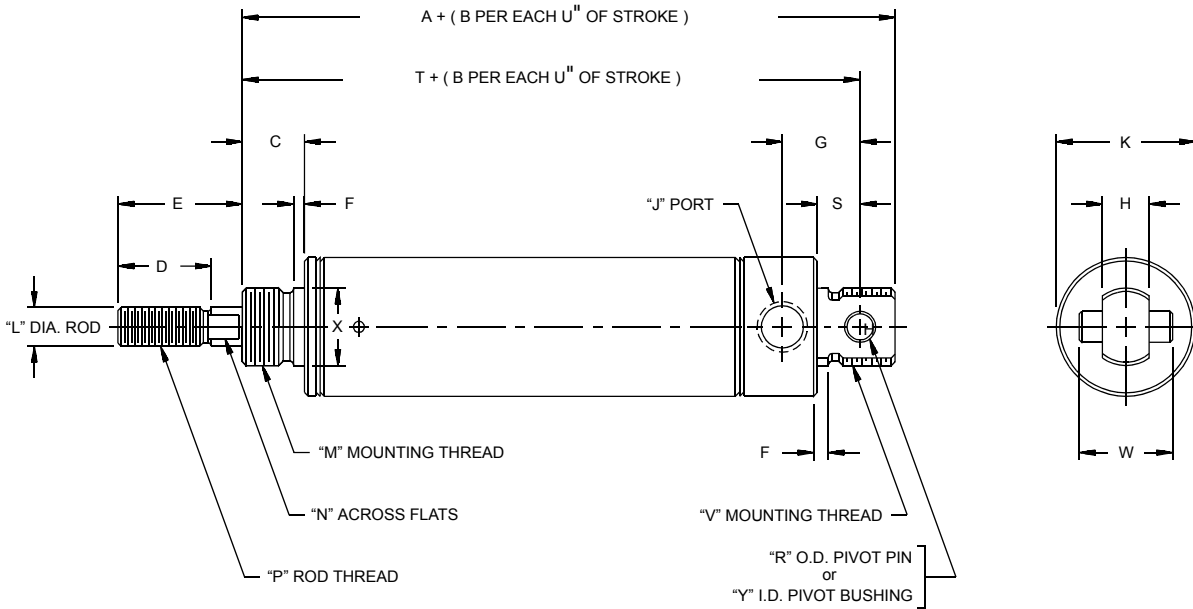

### 2" BORE LENGTHS

2" Bore		
Stroke	A + (B per U" of Stroke)	T + (B per U" of Stroke)
0.50	5.90	5.46
1.00	6.40	5.96
1.50	7.90	7.46

2" Bore		
Stroke	A + (B per U" of Stroke)	T + (B per U" of Stroke)
2.00	8.40	7.96
3.00	9.65	9.21
4.00	12.59	12.15

## Stainless Body Series - Model SVS - Single Acting Universal Mount

Bore	Dimension																			Mounting Accessories					
	A	B	C	D	E	F	G	H	J	K	L	M	N	P	R	S	T	U	V	W	X	Y	Foot Bkt.	Pivot Bkt.	Rod Clevis
5/16"	1.67	0.75	.25	.37	0.37	.04	0.34	.25	10-32	▼	.12	1/4-28	---	5-40	---	.18	1.51	0.50	3/8-24	---	0.25	.12	M01SS	M03SP	M04S
7/16"	2.00	0.93	.31	.50	0.50	.05	0.43	.31	10-32	●	.18	3/8-24	---	10-32	.15	.25	1.75	0.50	7/16-20	0.50	0.37	---	M11SS	M13S	M14S
9/16"	2.00	1.62	.37	.50	0.50	.05	0.43	.31	10-32	0.62	.18	7/16-20	---	10-32	.15	.25	1.81	1.00	7/16-20	0.50	0.43	---	M11SD	M13S	M14S
3/4"	2.56	1.68	.43	.50	0.50	.05	0.62	.37	1/8 NPT	+	.25	1/2-20	.21	1/4-28	.25	.34	2.28	1.00	5/8-18	0.75	0.50	---	M21SS	M23S	M24S
7/8"	2.75	1.56	.50	.50	0.50	.06	0.62	.37	1/8 NPT	0.93	.25	5/8-18	.21	1/4-28	.25	.34	2.46	1.00	5/8-18	0.75	0.62	---	M21	M23S	M24S
1 1/16"	2.81	1.56	.50	.50	0.50*	.06	0.62	.37	1/8 NPT	1.12	.31	5/8-18	.25	5/16-24	.25	.34	2.53	1.00	5/8-18	0.75	0.62	---	M21	M23S	M24
1 1/4"	3.53	1.81	.62	.75	1.00	.09	0.71	.50	1/8 NPT	1.34	.43	3/4-16	.37	7/16-20	.25	.40	3.12	1.00	3/4-16	0.87	0.75	---	M61S	M23S	M64S
1 1/2"	3.25	1.68	.62	.75	1.00	.09	0.81	.62	1/8 NPT	1.56	.43	3/4-16	.37	7/16-20	.37	.50	2.87	1.00	◆	1.00	0.75	---	M61S	M63S	M64S
1 3/4"	4.21	2.00	.75	.87	1.18	.09	1.12	.62	1/4 NPT	1.84	.50	1-14	.43	1/2-20	---	.50	3.71	1.00	1-14	---	1.03	.37	M71S	M73SP	M94
2"	☆	☆	.81	.87	1.25	.10	0.93	.75	1/4 NPT	2.09	.62	1 1/4-12	.56	1/2-20	---	.56	☆	☆	1 1/4-12	---	1.37	.37	M81S	M93	M94

NOTES

- ▼ 5/16" Bore Front Head Dia. = .36", Rear Head Dia. = 0.43"
- 7/16" Bore Front Head Dia. = .48", Rear Head Dia. = 0.74"
- + 3/4" Bore Front Head Dia. = .81", Rear Head Dia. = 0.86"
- \* Specify Option No. 1 to increase rod extension an additional 1/8"; thread length remains 0.50.
- ◆ 1.00" Dia. Unthreaded, specify Option No. 3 for 3/4-16 UNF x 5/8 long unmilled, threaded rear mounting stud; overall length reduces 0.25".
- ☆ See chart above for 2" bore length dimensions.

## SINGLE ACTING NON-ROTATING: Nose Mount

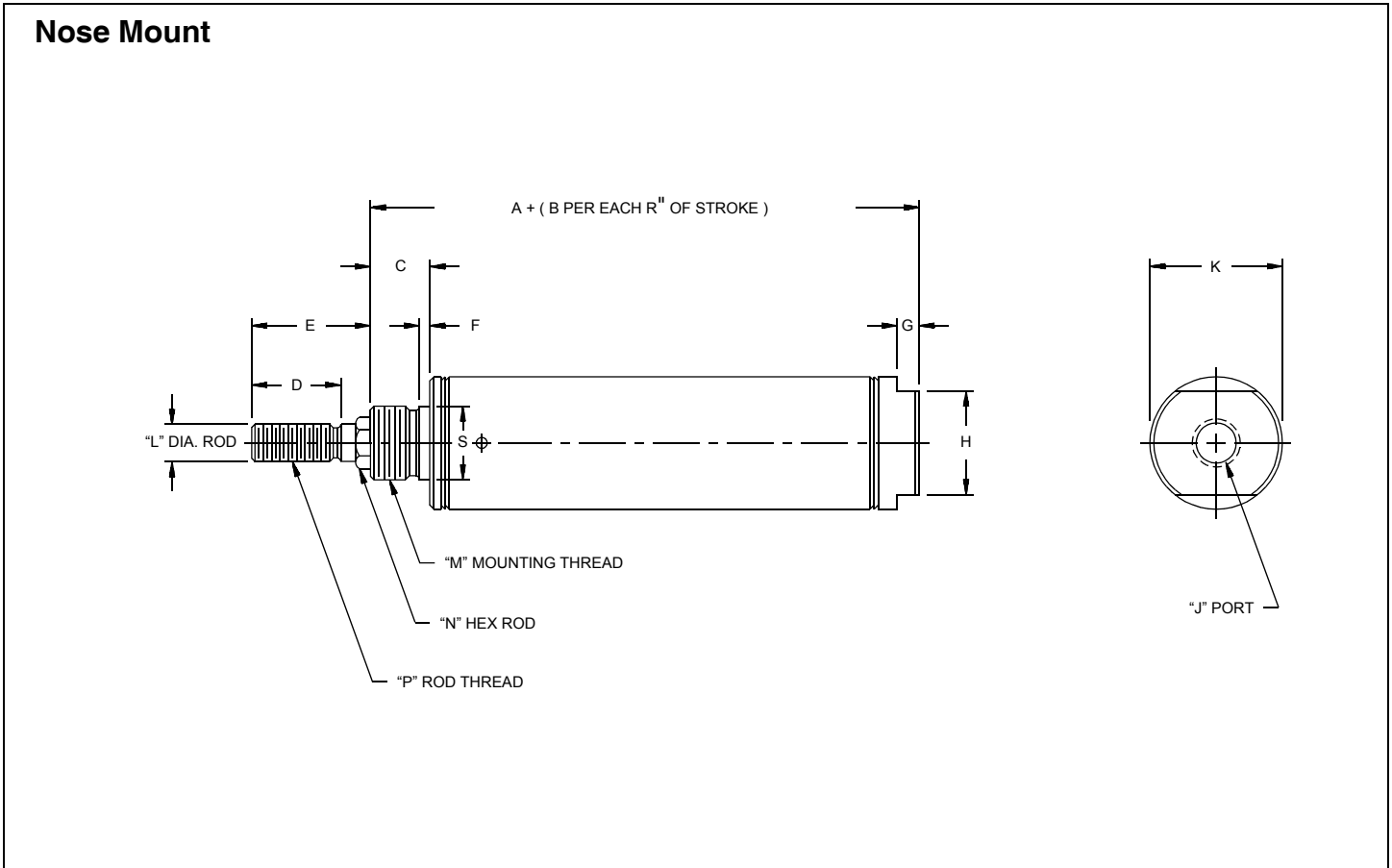

### Stainless Body Series - Model SNHS - Single Acting Non-Rotating Nose Mount

Bore	Dimension																Mounting Accessories		
	A	B	C	D	E	F	G	H	J	K	L	M	N	P	R	S	Foot Bkt.	Rod Clevis	Mtg. Nut
5/16"	1.12	0.75	.25	.37	0.37	.04	---	---	10-32	0.36	.12	1/4-28	1/8"	5-40	0.50	0.25	M01SS	M04S	M05SS
7/16"	1.31	0.93	.31	.50	0.75	.05	.18	0.37	10-32	0.48	.18	3/8-24	3/16"	10-32	0.50	0.37	M11SS	M14S	M15SS
9/16"	1.46	1.62	.37	.50	0.75	.05	.18	0.50	10-32	0.62	.18	7/16-20	3/16"	10-32	1.00	0.43	M11SD	M14S	M15SD
3/4"	1.50	1.68	.43	.50	0.75	.05	.18	0.62	1/8NPT	0.81	.25	1/2-20	1/4"	1/4-28	1.00	0.50	M21SS	M24S	M25SS
7/8"	1.84	1.56	.50	.50	0.75	.06	.18	0.62	1/8NPT	0.93	.25	5/8-18	1/4"	1/4-28	1.00	0.62	M21	M24S	M25
1 1/16"	1.93	1.56	.50	.50	0.75	.06	.18	0.87	1/8NPT	1.12	.31	5/8-18	3/8"	5/16-24	1.00	0.62	M21	M24	M25
1 1/4"	2.40	1.81	.62	.87	1.12	.09	.18	0.87	1/8NPT	1.34	.43	3/4-16	7/16"	7/16-20	1.00	0.75	M61S	M64S	M45
1 1/2"	2.18	1.68	.62	.87	1.25	.09	.25	0.87	1/8NPT	1.56	.43	3/4-16	7/16"	7/16-20	1.00	0.75	M61S	M64S	M45

# SINGLE ACTING NON-ROTATING: Universal Mount

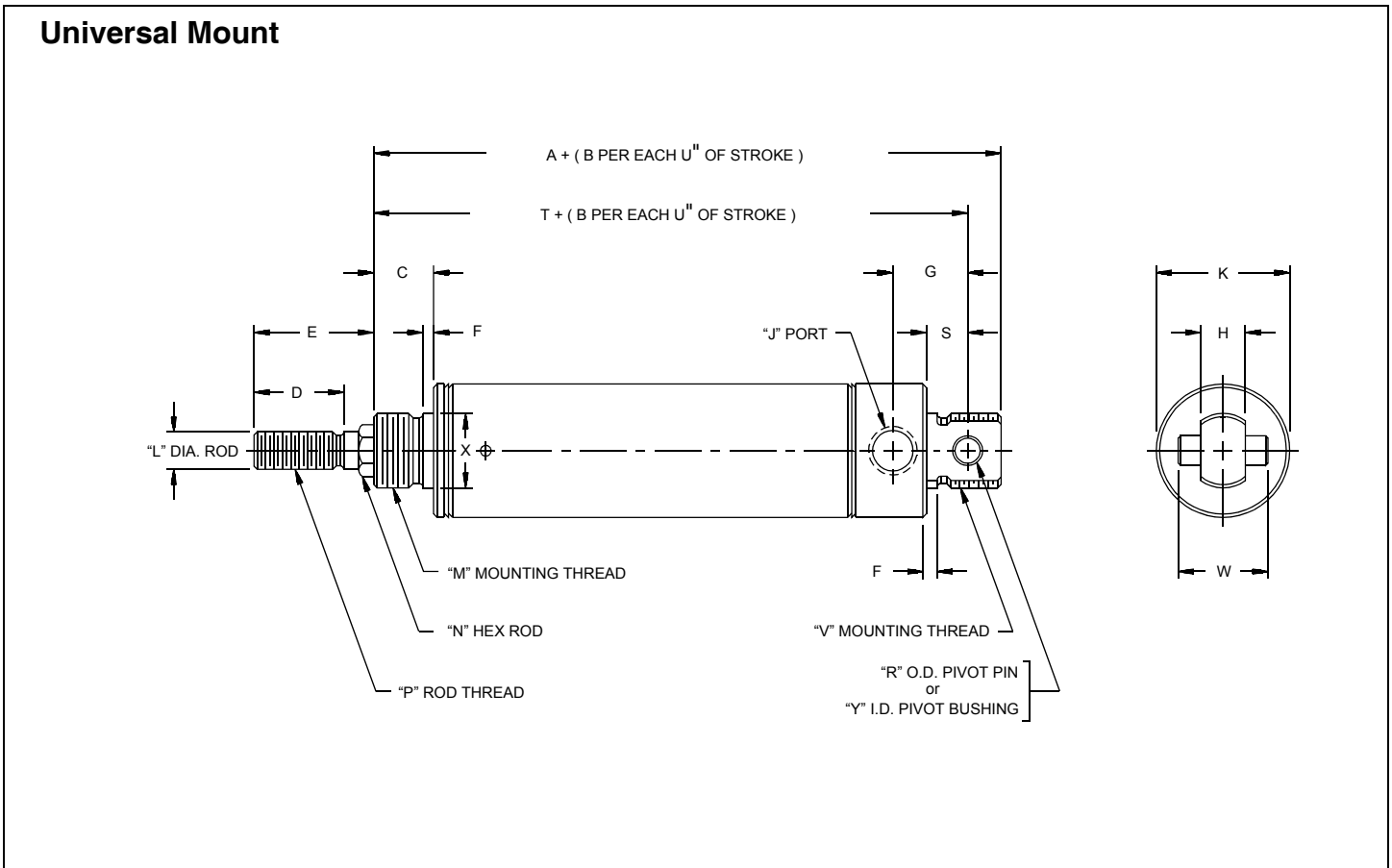

## Stainless Body Series - Model SVHS - Single Acting Non-Rotating Universal Mount

Bore	Dimension																			Mounting Accessories					
	A	B	C	D	E	F	G	H	J	K	L	M	N	P	R	S	T	U	V	W	X	Y	Foot Bkt.	Pivot Bkt.	Rod Clevis
5/16"	1.67	0.75	.25	.37	0.37	.04	.34	.25	10-32	▼	.12	1/4-28	1/8"	5-40	---	.18	1.51	0.50	3/8-24	---	0.25	.12	M01SS	M03SP	M04S
7/16"	2.00	0.93	.31	.50	0.75	.05	.43	.31	10-32	●	.18	3/8-24	3/16"	10-32	.15	.25	1.75	0.50	7/16-20	0.50	0.37	---	M11SS	M13S	M14S
9/16"	2.00	1.62	.37	.50	0.75	.05	.43	.31	10-32	0.62	.18	7/16-20	3/16"	10-32	.15	.25	1.81	1.00	7/16-20	0.50	0.43	---	M11SD	M13S	M14S
3/4"	2.56	1.68	.43	.50	0.75	.05	.62	.37	1/8 NPT	+	.25	1/2-20	1/4"	1/4-28	.25	.34	2.28	1.00	5/8-18	0.75	0.50	---	M21SS	M23S	M24S
7/8"	2.75	1.56	.50	.50	0.75	.06	.62	.37	1/8 NPT	0.93	.25	5/8-18	1/4"	1/4-28	.25	.34	2.46	1.00	5/8-18	0.75	0.62	---	M21	M23S	M24S
1 1/16"	2.81	1.56	.50	.50	0.75	.06	.62	.37	1/8 NPT	1.12	.31	5/8-18	3/8"	5/16-24	.25	.34	2.53	1.00	5/8-18	0.75	0.62	---	M21	M23S	M24
1 1/4"	3.53	1.81	.62	.87	1.12	.09	.71	.50	1/8 NPT	1.34	.43	3/4-16	7/16"	7/16-20	.25	.40	3.12	1.00	3/4-16	0.87	0.75	---	M61S	M23S	M64S
1 1/2"	3.25	1.68	.62	.87	1.25	.09	.81	.62	1/8 NPT	1.56	.43	3/4-16	7/16"	7/16-20	.37	.50	2.87	1.00	◆	1.00	0.75	---	M61S	M63S	M64S

**N** ▼ 5/16" Bore Front Head Dia. = .36", Rear Head Dia. = 0.43"  
**O** ● 7/16" Bore Front Head Dia. = .48", Rear Head Dia. = 0.74"  
**T** + 3/4" Bore Front Head Dia. = .81", Rear Head Dia. = 0.86"  
**E** ◆ 1.00" Dia. Unthreaded, specify Option No. 3 for 3/4-16 UNF x 5/8 long unmilled, threaded rear mounting stud; overall length reduces 0.25".  
**S**

# SINGLE ACTING: Block Front Mount, Block Front Trunnion Mount

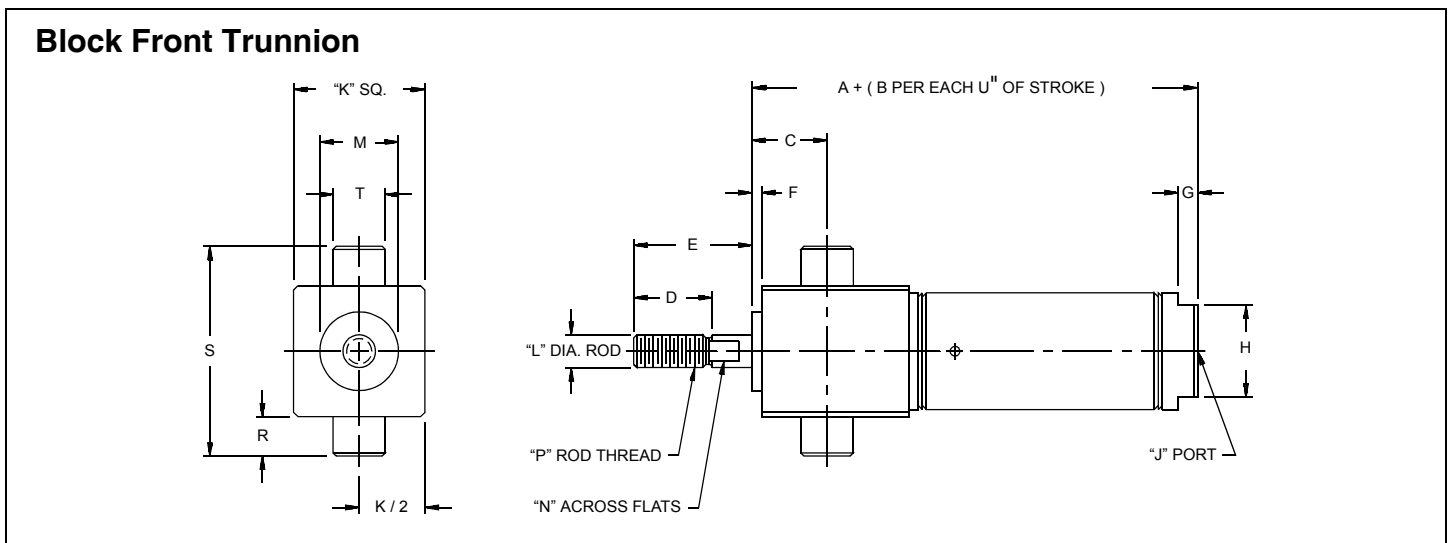
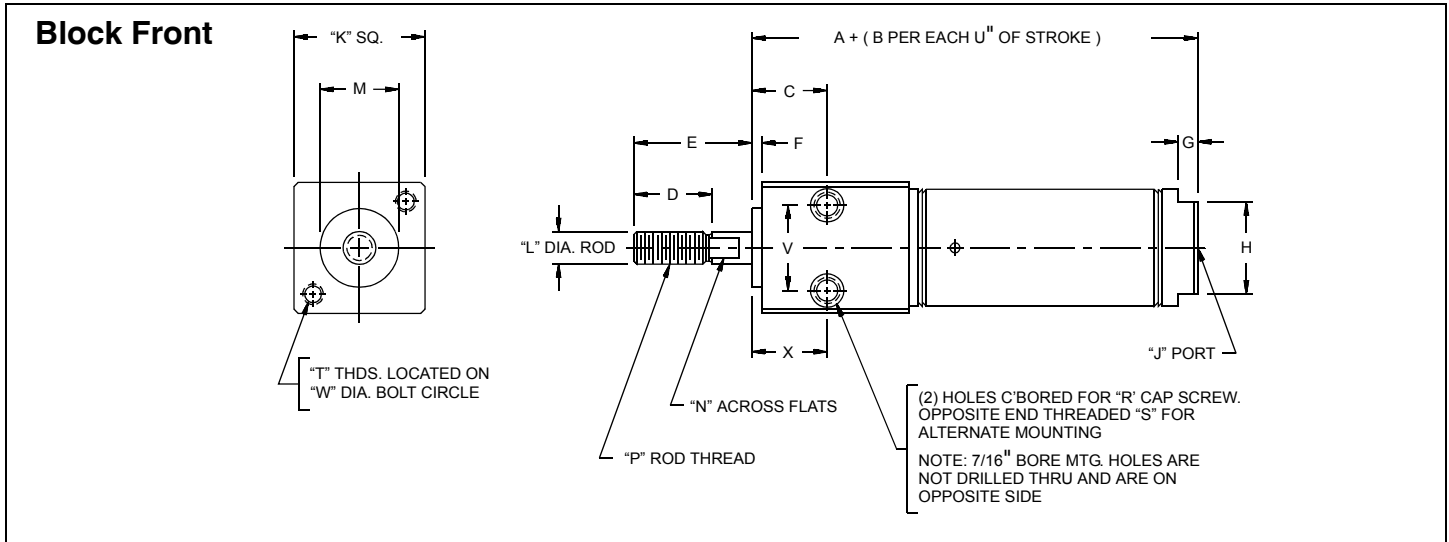

## Stainless Body Series - Model SBFS - Single Acting Block Front Mount

Bore	Dimension																				
	A	B	C	D	E	F	G	H	J	K	L	M	N	P	R	S	T	U	V	W	X
7/16"	1.93	0.93	0.31	0.50	0.50	.06	.18	.37	10-32	0.75	.18	0.43	---	10-32	N/A	8-32	8-32	0.50	0.43	0.75	0.75
3/4"	2.40	1.68	0.46	0.75	1.00	.09	.18	.62	1/8 NPT	1.00	.25	0.62	.21	1/4-28	#10	1/4-20	10-32	1.00	0.62	1.00	0.46
1 1/16"	3.00	1.81	0.71	0.75	1.12	.09	.18	.87	1/8 NPT	1.25	.31	0.75	.25	5/16-24	#10	1/4-20	10-32	1.00	0.81	1.25	0.71
1 1/2"	3.75	1.68	1.00	1.25	1.50	.12	.25	.87	1/4 NPT	1.75	.43	1.00	.37	7/16-20	1/4"	5/16-18	1/4-20	1.00	1.12	1.75	1.00

## Stainless Body Series - Model SBFTS - Single Acting Block Front Trunnion Mount

Bore	Dimension																		Mounting Accessory
	A	B	C	D	E	F	G	H	J	K	L	M	N	P	R	S	T	U	Bkt. No.
7/16"	1.93	0.93	0.31	0.50	0.50	.06	.18	.37	10-32	0.75	.18	0.43	---	10-32	.25	1.25	.37	0.50	M17S
3/4"	2.40	1.68	0.43	0.75	1.00	.09	.18	.62	1/8 NPT	1.00	.25	0.62	.21	1/4-28	.37	1.75	.50	1.00	M37S
1 1/16"	3.00	1.81	0.71	0.75	1.12	.09	.18	.87	1/8 NPT	1.25	.31	0.75	.25	5/16-24	.37	2.00	.50	1.00	M37S
1 1/2"	3.75	1.68	1.06	1.25	1.50	.12	.25	.87	1/4 NPT	1.75	.43	1.00	.37	7/16-20	.37	2.50	.50	1.00	M37S

## SINGLE ACTING: Block Rear Mount, Block Rear Trunnion Mount

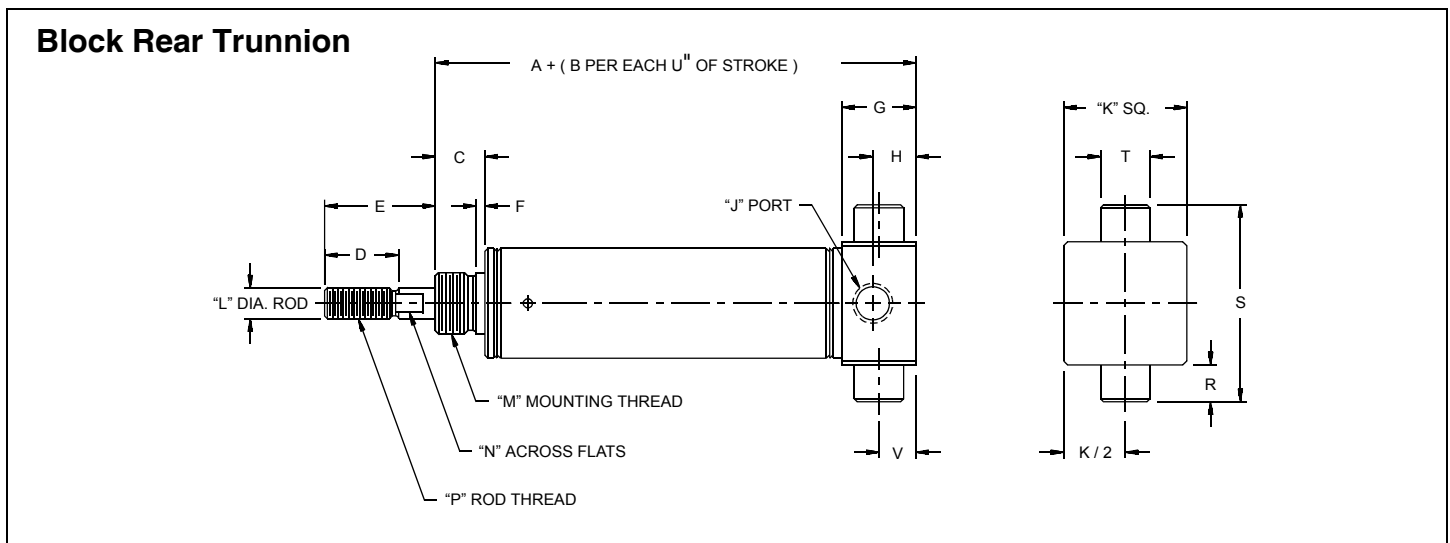
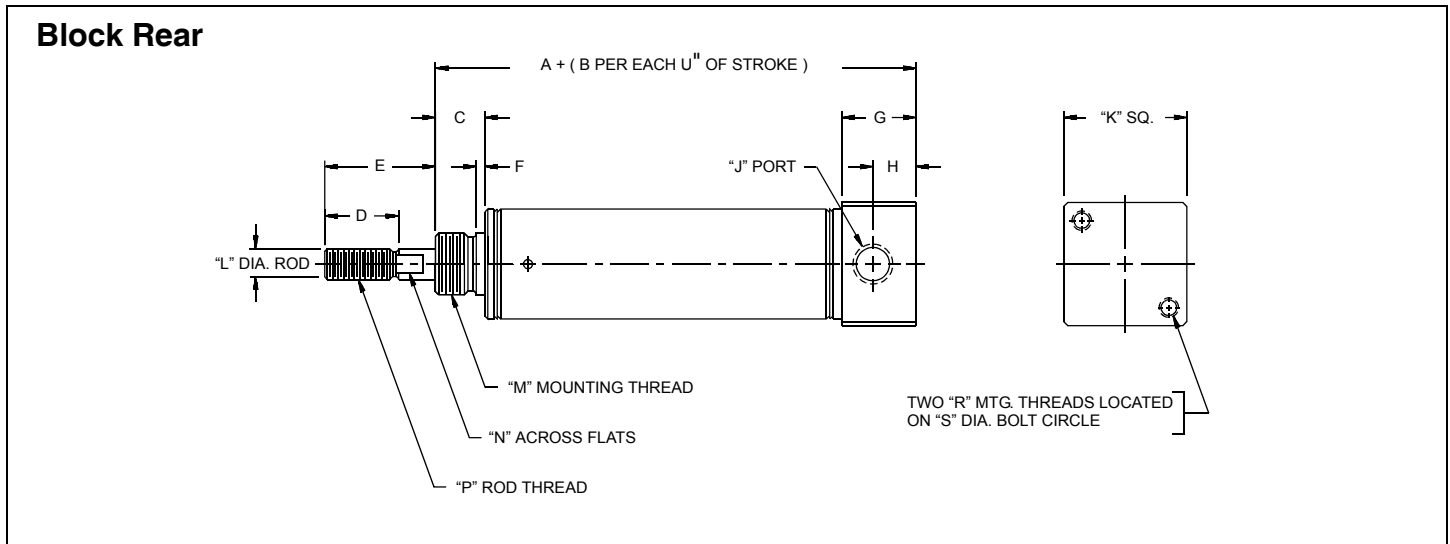

### Stainless Body Series - Model SBRS - Single Acting Block Rear Mount

Bore	Dimension																	
	A	B	C	D	E	F	G	H	J	K	L	M	N	P	R	S	U	
7/16"	1.62	0.93	.31	0.50	0.50	.05	0.50	.34	10-32	0.75	.18	3/8-24	---	10-32	8-32	0.75	0.50	
3/4"	2.06	1.68	.43	0.75	1.00	.05	0.75	.43	1/8 NPT	1.00	.25	1/2-20	.21	1/4-28	10-32	1.00	1.00	
1 1/16"	2.43	1.81	.50	0.75	1.12	.09	0.75	.43	1/8 NPT	1.25	.31	5/8-18	.25	5/16-24	10-32	1.25	1.00	
1 1/2"	2.81	2.00	.62	1.25	1.50	.09	1.00	.62	1/4 NPT	1.75	.43	3/4-16	.37	7/16-20	1/4-20	1.75	1.00	

### Stainless Body Series - Model SBRTS - Single Acting Block Rear Trunnion Mount

Bore	Dimension																		Mounting Accessory	
	A	B	C	D	E	F	G	H	J	K	L	M	N	P	R	S	T	U	V	Bkt. No.
7/16"	1.62	0.93	.31	0.50	0.50	.05	0.50	.34	10-32	0.75	.18	3/8-24	---	10-32	.25	0.75	.37	0.50	.25	M17S
3/4"	2.06	1.68	.43	0.75	1.00	.05	0.75	.43	1/8 NPT	1.00	.25	1/2-20	.21	1/4-28	.37	1.00	.50	1.00	.37	M37S
1 1/16"	2.43	1.81	.50	0.75	1.12	.09	0.75	.43	1/8 NPT	1.25	.31	5/8-18	.25	5/16-24	.37	1.25	.50	1.00	.37	M37S
1 1/2"	2.81	2.00	.62	1.25	1.50	.09	1.00	.62	1/4 NPT	1.75	.43	3/4-16	.37	7/16-20	.37	1.75	.50	1.00	.50	M37S



## DOUBLE ACTING: Nose Mount

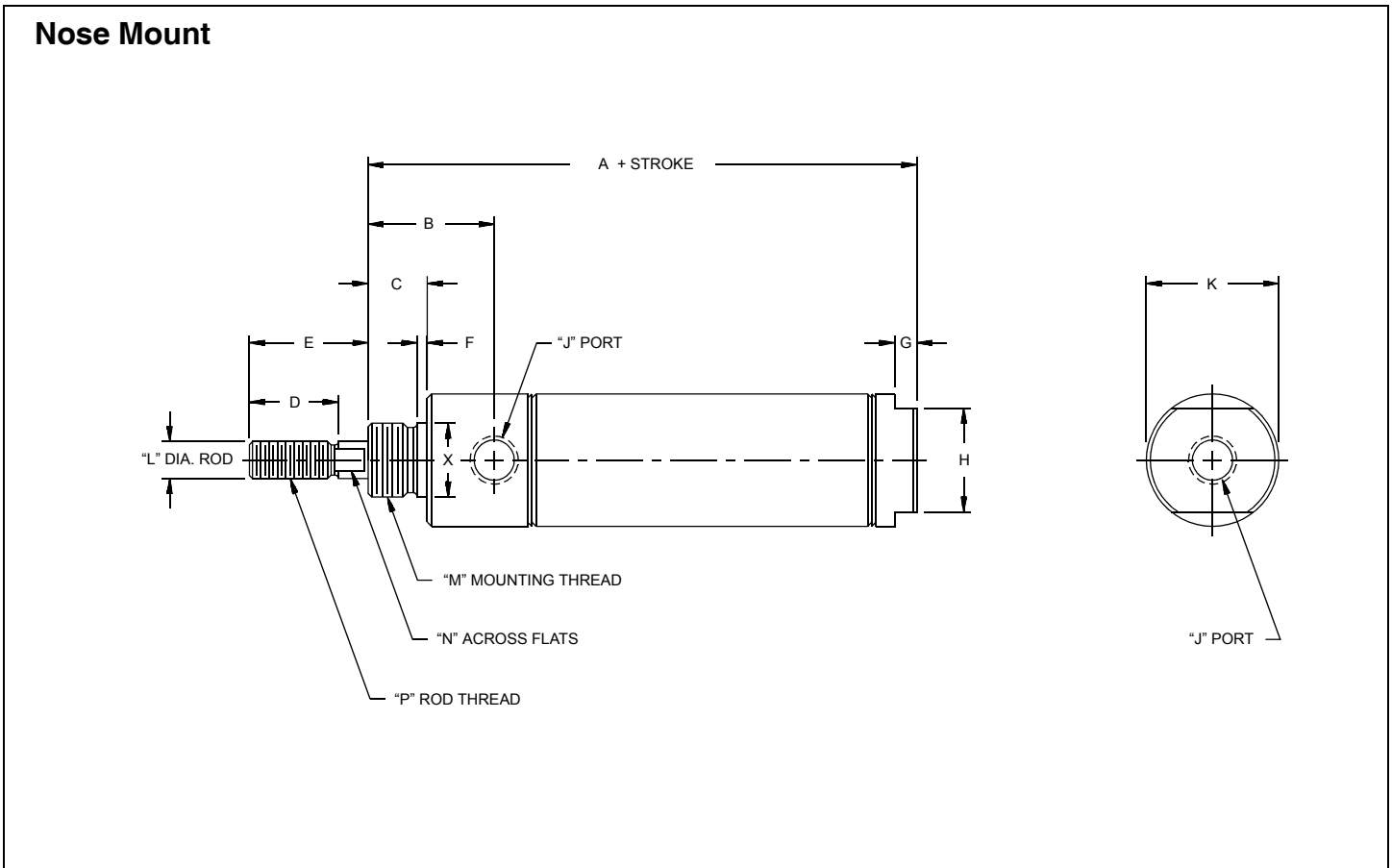

## Stainless Body Series - Model DNS - Double Acting Nose Mount

Dimension																Mounting Accessories		
Bore	A	B	C	D	E	F	G	H	J	K	L	M	N	P	X	Foot Bkt.	Rod Clevis	Mtg. Nut
5/16"	1.64	0.46	0.31	0.37	0.37	.03	--	---	10-32	0.50 <sup>▼</sup>	.12	3/8-24	--	5-40	0.37	M01SD	M04S	M15SS
7/16"	2.12	0.71	0.37	0.50	0.50	.05	.18	0.37	10-32	0.74	.18	7/16-20	--	10-32	0.43	M11SD	M14S	M15SD
9/16"	2.21	0.75	0.37	0.50	0.50	.05	.18	0.50	10-32	0.62	.18	7/16-20	--	10-32	0.43	M11SD	M14S	M15SD
3/4"	2.96	0.96	0.50	0.50	0.50	.06	.18	0.62	1/8NPT	0.86	.25	5/8-18	.21	1/4-28	0.62	M21	M24S	M25
7/8"	2.93	0.96	0.50	0.50	0.50	.09	.18	0.62	1/8NPT	0.93	.25	5/8-18	.21	1/4-28	0.62	M21	M24S	M25
1 1/16"	3.12	1.06	0.50	0.50	0.50 <sup>*</sup>	.09	.18	0.87	1/8NPT	1.12	.31	5/8-18	.25	5/16-24	0.62	M21	M24	M25
1 1/4"	3.75	1.18	0.62	0.75	1.00	.09	.18	0.87	1/8NPT	1.34	.43	3/4-16	.37	7/16-20	0.75	M61S	M64S	M45
1 1/2"	3.43	1.25	0.62	0.75	1.00	.09	.25	0.87	1/8NPT	1.56	.43	3/4-16	.37	7/16-20	0.75	M61S	M64S	M45
1 3/4"	4.37	1.62	0.75	0.87	1.18	.09	.25	1.25	1/4NPT	1.84	.50	1-14	.43	1/2-20	1.03	M71S	M94	M65
2"	4.31	1.50	0.81	0.87	1.25	.10	.25	1.25	1/4NPT	2.09	.62	1 1/4-12	.56	1/2-20	1.37	M81S	M94	M85
3"	4.87	1.71	1.00	1.25	1.62	.18	.31	2.00	3/8NPT	3.12	.75	1 1/2-12	.62	5/8-18	1.62	M101S	M104S	M105S

N  
O  
T  
E  
S

- \* Specify Option No. 1 to increase rod extension an additional 1/8"; thread length remains 0.50.
- ▼ 5/16" Bore Front Head is .50" square, .62" dia. across corners, Rear Head O.D. = .36" dia.

## DOUBLE ACTING: Universal Mount

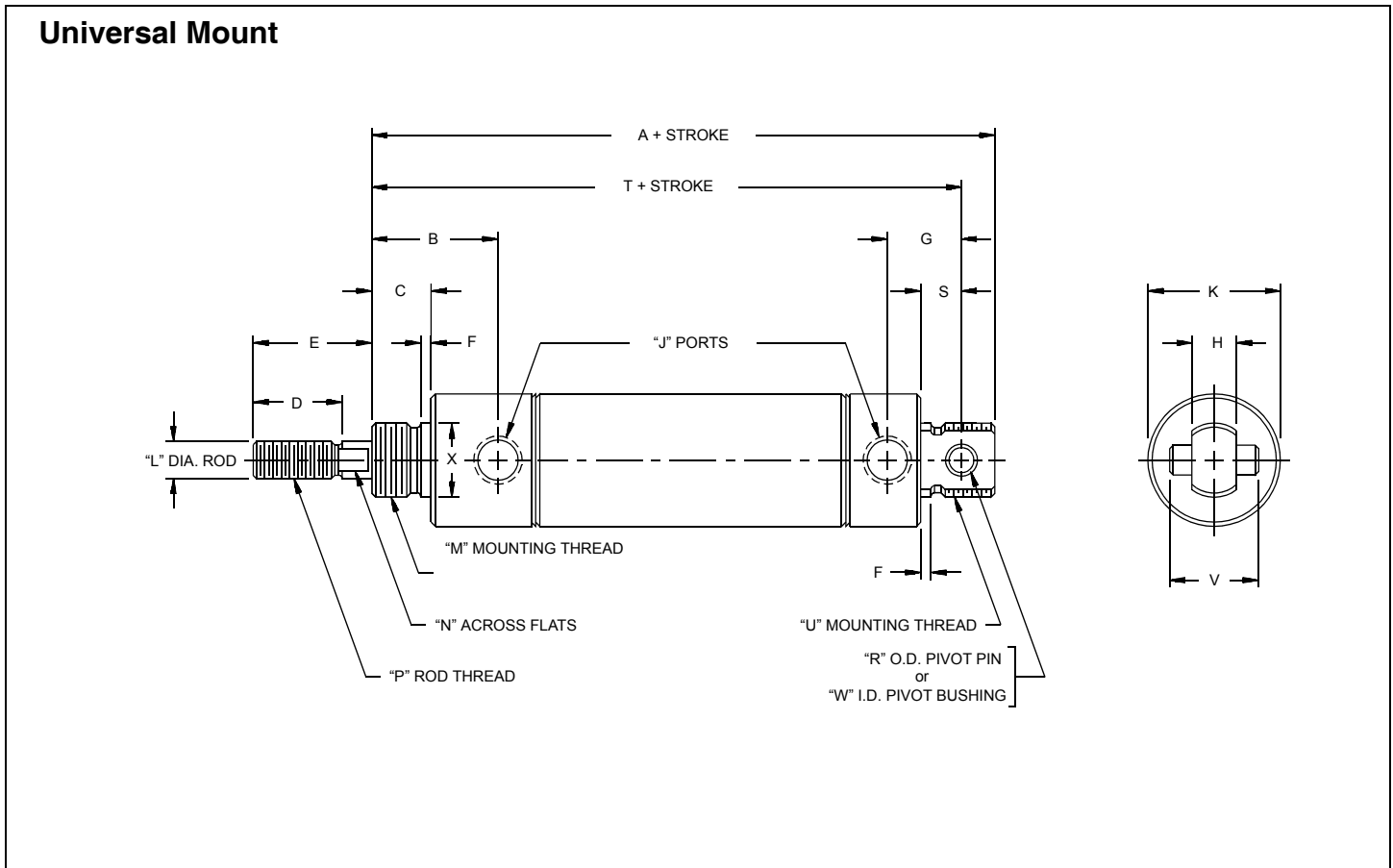

## Stainless Body Series - Model DVS - Double Acting Universal Mount

Dimension																				Mounting Accessories				
Bore	A	B	C	D	E	F	G	H	J	K	L	M	N	P	R	S	T	U	V	W	X	Foot Bkt.	Pivot Bkt.	Rod Clevis
5/16"	2.18	0.46	0.31	0.37	0.37	.03	0.34	.25	10-32	0.50	.12	3/8-24	--	5-40	--	.18	2.03	3/8-24	---	.12	0.37	M01SD	M03SP	M04S
7/16"	2.81	0.71	0.37	0.50	0.50	.05	0.43	.31	10-32	0.74	.18	7/16-20	--	10-32	.15	.25	2.56	7/16-20	0.50	--	0.43	M11SD	M13S	M14S
9/16"	2.75	0.75	0.37	0.50	0.50	.05	0.43	.31	10-32	0.62	.18	7/16-20	--	10-32	.15	.25	2.56	7/16-20	0.50	--	0.43	M11SD	M13S	M14S
3/4"	4.03	0.96	0.50	0.50	0.50	.06	0.62	.37	1/8NPT	0.86	.25	5/8-18	.21	1/4-28	.25	.34	3.75	5/8-18	0.75	--	0.62	M21	M23S	M24S
7/8"	3.84	0.96	0.50	0.50	0.50	.09	0.62	.37	1/8NPT	0.93	.25	5/8-18	.21	1/4-28	.25	.34	3.56	5/8-18	0.75	--	0.62	M21	M23S	M24S
1 1/16"	4.00	1.06	0.50	0.50	0.50*	.09	0.62	.37	1/8NPT	1.12	.31	5/8-18	.25	5/16-24	.25	.34	3.71	5/8-18	0.75	--	0.62	M21	M23S	M24
1 1/4"	4.87	1.18	0.62	0.75	1.00	.09	0.71	.50	1/8NPT	1.34	.43	3/4-16	.37	7/16-20	.25	.40	4.46	3/4-16	0.87	--	0.75	M61S	M23S	M64S
1 1/2"	4.50	1.25	0.62	0.75	1.00	.09	0.81	.62	1/8NPT	1.56	.43	3/4-16	.37	7/16-20	.37	.50	4.12	◆	1.00	--	0.75	M61S	M63S	M64S
1 3/4"	5.93	1.62	0.75	0.87	1.18	.09	1.12	.62	1/4NPT	1.84	.50	1-14	.43	1/2-20	--	.50	5.43	1-14	---	.37	1.03	M71S	M73SP	M94
2"	5.68	1.50	0.81	0.87	1.25	.10	0.93	.75	1/4NPT	2.09	.62	1 1/4-12	.56	1/2-20	--	.56	5.25	1 1/4-12	---	.37	1.37	M81S	M93	M94
3"	6.75	1.71	1.00	1.25	1.62	.18	1.34	.87	3/8NPT	3.12	.75	1 1/2-12	.62	5/8-18	--	.81	6.12	1 1/2-12	---	.50	1.62	M101S	M103SP	M104S

N O T E S  
 \* Specify Option No. 1 to increase rod extension an additional 1/8"; thread length remains 0.50.  
 ▼ 5/16" Bore Front Head is .50" square, 0.62" diameter across corners, Rear Head O.D. = 0.43" diameter.  
 ◆ 1.00" Diameter Unthreaded, specify Option No. 3 for 3/4-16 UNF x 5/8 long unmilled, threaded rear mounting stud; overall length reduces 0.25".

## DOUBLE ACTING: Block Front Mount, Block Front Trunnion Mount

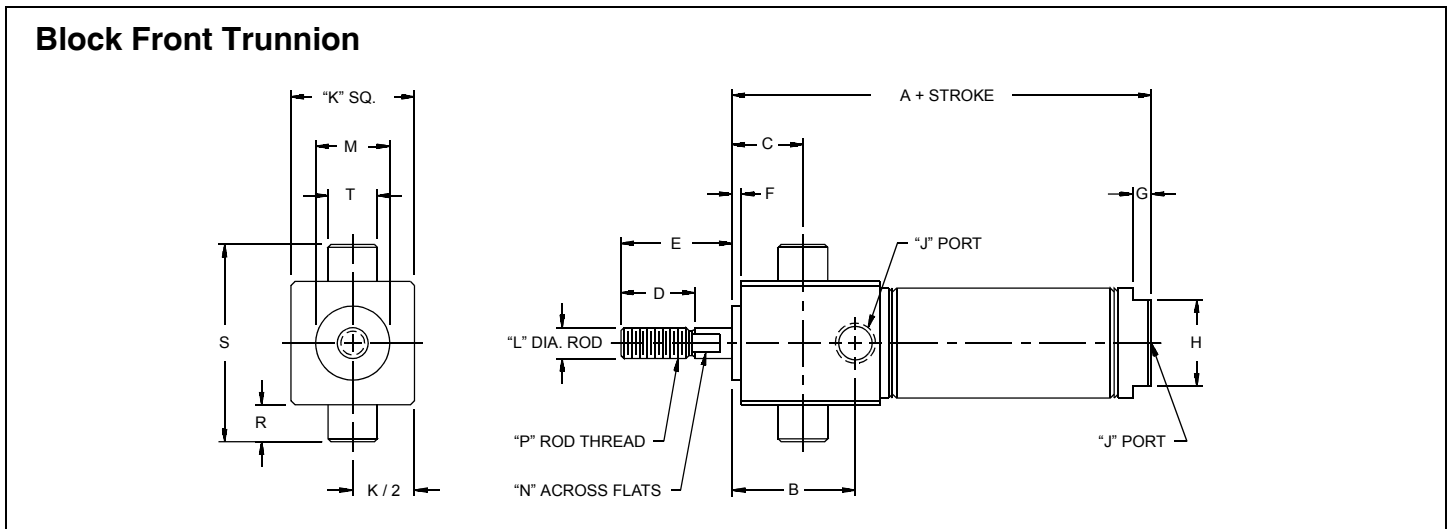
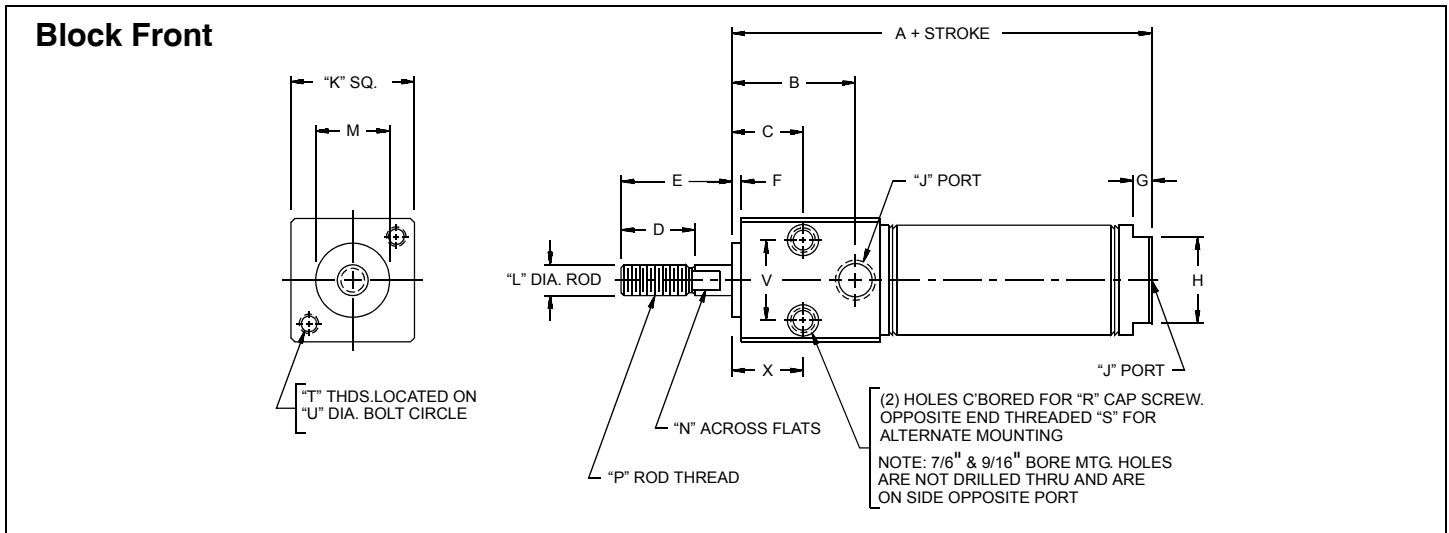

### Stainless Body Series - Model DBFS - Double Acting Block Front Mount

Bore	Dimension																			
	A	B	C	D	E	F	G	H	J	K	L	M	N	P	R	S	T	U	V	X
5/16"	1.71	0.41	0.59	0.37	0.37	--	--	--	10-32	0.50	.12	---	--	5-40	N/A	.11 ▲	----	---	0.34	0.59
7/16"	2.12	0.75	0.31	0.50	0.50	.06	.18	.37	10-32	0.75	.18	0.43	--	10-32	N/A	8-32	8-32	0.75	0.43	0.75
9/16"	2.21	0.75	0.31	0.50	0.50	.06	.18	.50	10-32	0.75	.18	0.43	--	10-32	N/A	8-32	8-32	0.75	0.43	0.75
3/4"	2.96	0.96	0.46	0.75	1.00	.09	.18	.62	1/8 NPT	1.00	.25	0.62	.21	1/4-28	#10	1/4-20	10-32	1.00	0.62	0.46
1 1/16"	3.37	1.25	0.71	0.75	1.12	.09	.18	.87	1/8 NPT	1.25	.31	0.75	.25	5/16-24	#10	1/4-20	10-32	1.25	0.81	0.71
1 1/2"	3.93	1.65	1.00	1.25	1.50	.12	.25	.87	1/4 NPT	1.75	.43	1.00	.37	7/16-20	1/4"	5/16-18	1/4-20	1.75	1.12	1.00

Note ▲ 5/16" Bore have .11 dia. unthreaded thru holes.

### Stainless Body Series - Model DBFTS - Double Acting Block Front Trunnion Mount

Bore	Dimension																	Mounting Accessory	
	A	B	C	D	E	F	G	H	J	K	L	M	N	P	R	S	T	Bkt. No.	
7/16"	2.12	0.75	0.31	0.50	0.50	.06	.18	.37	10-32	0.75	.18	0.43	--	10-32	.25	1.25	.37	M17S	
3/4"	2.96	0.96	0.43	0.75	1.00	.09	.18	.62	1/8 NPT	1.00	.25	0.62	.21	1/4-28	.37	1.75	.50	M37S	
1 1/16"	3.37	1.25	0.71	0.75	1.12	.09	.18	.87	1/8 NPT	1.25	.31	0.75	.25	5/16-24	.37	2.00	.50	M37S	
1 1/2"	3.93	1.65	1.06	1.25	1.50	.12	.25	.87	1/4 NPT	1.75	.43	1.00	.37	7/16-20	.37	2.50	.50	M37S	

## DOUBLE ACTING: Block Rear Mount, Block Rear Trunnion Mount

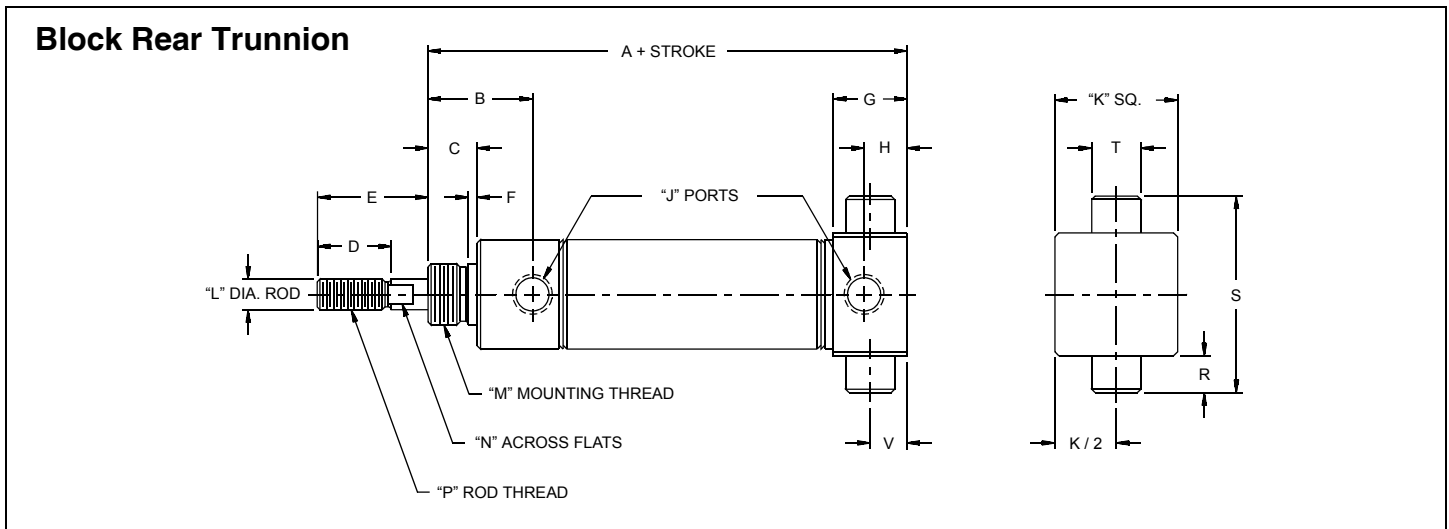
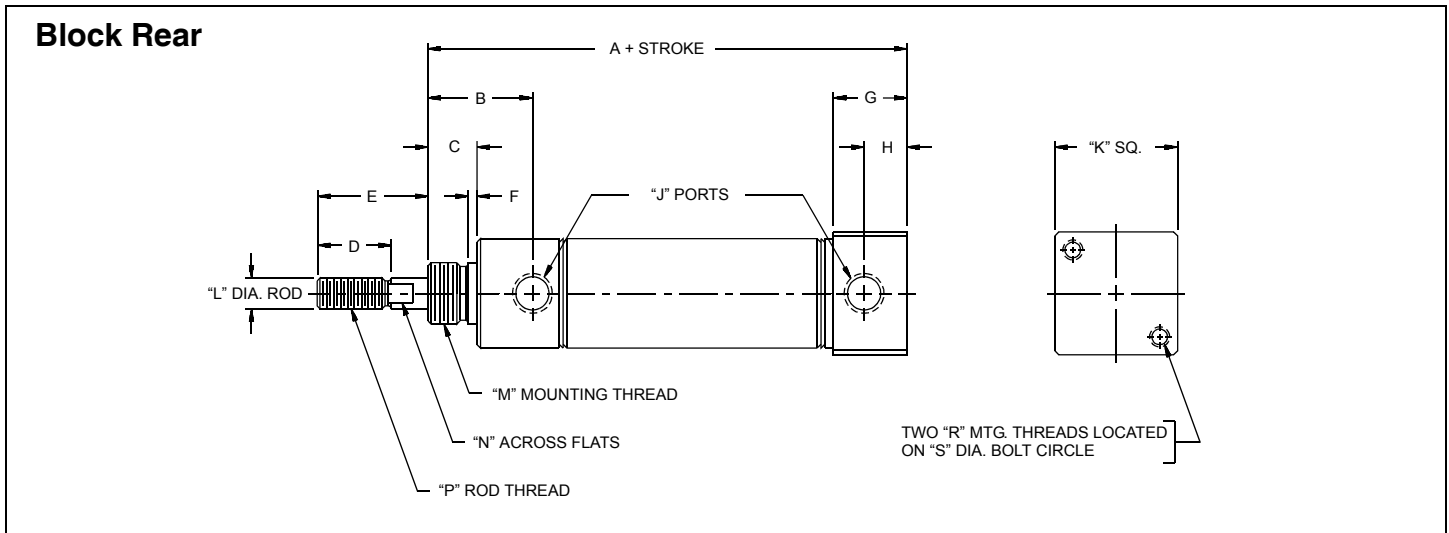

### Stainless Body Series - Model DBRS - Double Acting Block Rear Mount

Bore	Dimension															
	A	B	C	D	E	F	G	H	J	K	L	M	N	P	R	S
7/16"	2.43	0.71	.31	0.50	0.50	.05	0.50	.34	10-32	0.75	.18	7/16-20	---	10-32	8-32	0.75
3/4"	3.53	0.96	.50	0.75	1.00	.06	0.75	.43	1/8 NPT	1.00	.25	5/8-18	.21	1/4-28	10-32	1.00
1 1/16"	3.62	1.06	.50	0.75	1.12	.09	0.75	.43	1/8 NPT	1.25	.31	5/8-18	.25	5/16-24	10-32	1.25
1 1/2"	4.12	1.21	.62	1.25	1.50	.09	1.00	.62	1/4 NPT	1.75	.43	3/4-16	.37	7/16-20	1/4-20	1.75

### Stainless Body Series - Model DBRTS - Double Acting Block Rear Trunnion Mount

Bore	Dimension																	Mounting Accessory	
	A	B	C	D	E	F	G	H	J	K	L	M	N	P	R	S	T	V	Bkt. No.
7/16"	2.43	0.71	.37	0.50	0.50	.05	0.50	.34	10-32	0.75	.18	7/16-20	---	10-32	.25	1.25	.37	.25	M17S
3/4"	3.53	0.96	.50	0.75	1.00	.06	0.75	.43	1/8 NPT	1.00	.25	5/8-18	.21	1/4-28	.37	1.75	.50	.37	M37S
1 1/16"	3.62	1.06	.50	0.75	1.12	.09	0.75	.43	1/8 NPT	1.25	.31	5/8-18	.25	5/16-24	.37	2.00	.50	.37	M37S
1 1/2"	4.12	1.21	.62	1.25	1.50	.09	1.00	.62	1/4 NPT	1.75	.43	3/4-16	.37	7/16-20	.37	2.50	.50	.50	M37S

## DOUBLE ACTING: Double End Rod, Double End Hollow Rod

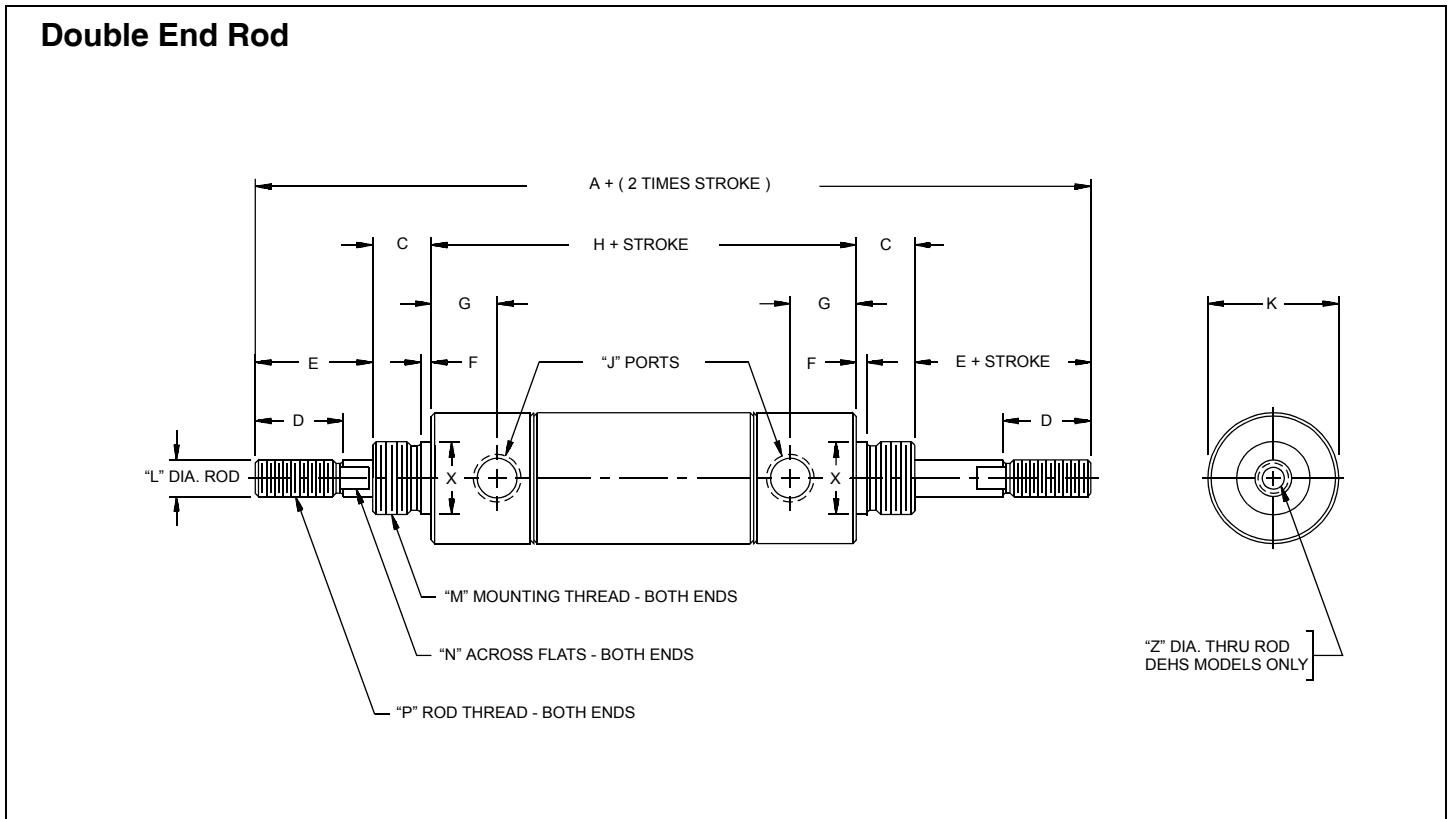

### Stainless Body Series - Model DES - Double End Rod

Dimension																Mounting Accessories		
Bore	A	C	D	E	F	G	H	J	K	L	M	N	P	X	Foot Bkt.	Rod Clevis	Mtg. Nut	
7/16"	3.81	0.37	0.50	0.50	.05	.34	2.06	10-32	0.74	.18	7/16-20	--	10-32	0.43	M11SD	M14S	M15SD	
9/16"	3.93	0.37	0.50	0.50	.06	.37	2.18	10-32	0.62	.18	7/16-20	--	10-32	0.43	M11SD	M14S	M15SD	
3/4"	5.00	0.50	0.50	0.50	.06	.46	3.00	1/8NPT	0.86	.25	5/8-18	.21	1/4-28	0.62	M21	M24S	M25	
7/8"	4.90	0.50	0.50	0.50	.09	.46	2.90	1/8NPT	0.93	.25	5/8-18	.21	1/4-28	0.62	M21	M24S	M25	
1 1/16"	5.00	0.50	0.50	0.62	.09	.56	2.75	1/8NPT	1.12	.31	5/8-18	.25	5/16-24	0.62	M21	M24	M25	
1 1/4"	7.06	0.62	0.75	1.00	.09	.56	3.81	1/8NPT	1.34	.43	3/4-16	.37	7/16-20	0.75	M61S	M64S	M45	
1 1/2"	6.62	0.62	0.75	1.00	.09	.62	3.37	1/8NPT	1.56	.43	3/4-16	.37	7/16-20	0.75	M61S	M64S	M45	
1 3/4"	8.31	0.75	0.87	1.18	.09	.87	4.43	1/4NPT	1.84	.50	1-14	.43	1/2-20	1.03	M71S	M94	M65	
2"	8.31	0.81	0.87	1.25	.10	.68	4.18	1/4NPT	2.09	.62	1 1/4-12	.56	1/2-20	1.37	M81S	M94	M85	
3"	9.81	1.00	1.25	1.62	.18	.71	4.56	3/8NPT	3.12	.75	1 1/2-12	.62	5/8-18	1.62	M101S	M104S	M105S	

### Stainless Body Series - Model DEHS - Double End Hollow Rod

Dimension																	Mounting Accessories		
Bore	A	C	D	E	F	G	H	J	K	L	M	N	P	X	Z	Foot Bkt.	Rod Clevis	Mtg. Nut	
3/4"	5.00	.50	.50	0.50	.06	.46	3.00	1/8NPT	0.86	.25	5/8-18	.21	1/4-28	0.62	.06	M21	M24S	M25	
1 1/16"	5.00	.50	.50	0.62	.09	.56	2.75	1/8NPT	1.12	.31	5/8-18	.25	5/16-24	0.62	.18	M21	M24	M25	
1 1/4"	7.06	.62	.75	1.00	.09	.56	3.81	1/8NPT	1.34	.43	3/4-16	.37	7/16-20	0.75	.25	M61S	M64S	M45	
1 1/2"	6.62	.62	.75	1.00	.09	.62	3.37	1/8NPT	1.56	.43	3/4-16	.37	7/16-20	0.75	.25	M61S	M64S	M45	



## VOLUME CHAMBERS

### Volume Chamber

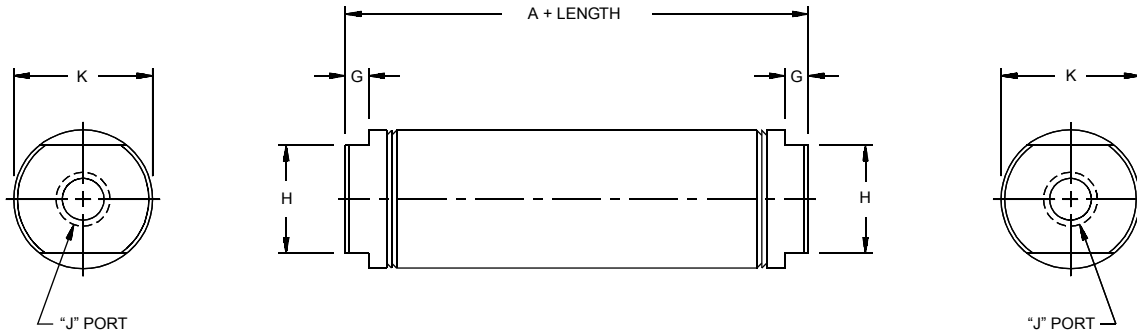

### Stainless Body Series - Model VCS\*

Bore	Model No.	Dimension					Volume (In <sup>3</sup> )
		A	G	H	J	K	
5/16"	312VCS- □.□□	1.03	--	---	#10-32	0.36	.03 + .07 per Inch
7/16"	437VCS- □.□□	1.43	.18	0.37	#10-32	0.48	.07 + .15 per Inch
9/16"	562VCS- □.□□	1.56	.18	0.50	#10-32	0.62	.17 + .25 per Inch
3/4"	750VCS- □.□□	1.90	.18	0.62	1/8NPT	0.81	.44 + .44 per Inch
7/8"	875VCS- □.□□	1.96	.18	0.62	1/8NPT	0.93	.59 + .60 per Inch
1 1/16"	1062VCS- □.□□	2.12	.18	0.87	1/8NPT	1.12	.85 + .89 per Inch
1 1/4"	1250VCS- □.□□	2.56	.18	0.87	1/8NPT	1.34	1.64 + 1.23 per Inch
1 1/2"	1500VCS- □.□□	2.25	.25	0.87	1/8NPT	1.56	1.92 + 1.77 per Inch
1 3/4"	1750VCS- □.□□	2.81	.25	1.25	1/4NPT	1.84	3.20 + 2.40 per Inch
2"	2000VCS- □.□□	2.81	.25	1.25	1/4NPT	2.09	3.95 + 3.14 per Inch
3"	3000VCS- □.□□	3.18	.31	2.00	3/8NPT	3.12	10.38 + 7.07 per Inch

NOTES

□ Enter desired length to two decimal places to complete Model Number.

\* Standard lengths for Volume Chambers are identical to the standard Double Acting stroke lengths listed on Page 5.

## REVERSE ACTING: Nose Mount

### Nose Mount

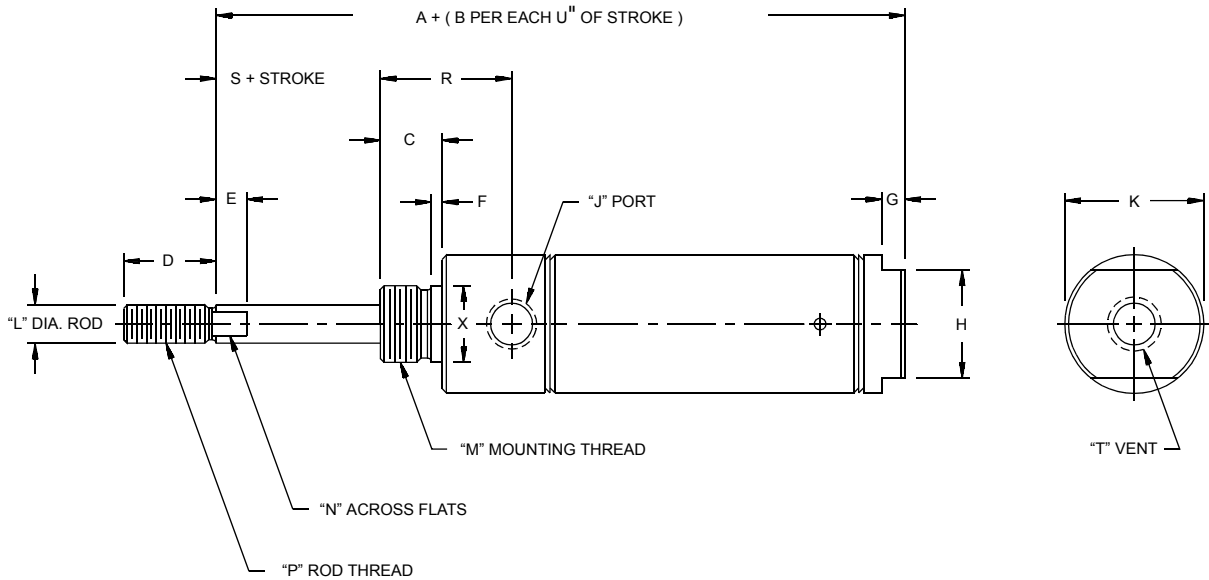

### 2" BORE LENGTHS

2" Bore	
Stroke	A + (B per U" of Stroke)
0.50	6.10
1.00	7.10

2" Bore	
Stroke	A + (B per U" of Stroke)
1.50	9.10
2.00	10.10

2" Bore	
Stroke	A + (B per U" of Stroke)
3.00	12.34
4.00	16.34

## Stainless Body Series - Model RNS - Reverse Acting Nose Mount

Bore	Dimension																		Mounting Accessories			
	A	B	C	D	E	F	G	H	J	K	L	M	N	P	R	S	T	U	X	Foot Bkt.	Rod Clevis	Mtg. Nut
5/16"	1.48	1.25	.31	0.37	--	.03	--	--	10-32	▼	.12	3/8-24	--	5-40	0.46	0.00	10-32	0.50	0.37	M01SD	M04S	M15SS
7/16"	1.81	1.43	.37	0.50	--	.05	--	--	10-32	●	.18	7/16-20	--	10-32	0.71	0.00	----	0.50	0.43	M11SD	M14S	M15SD
9/16"	1.93	2.62	.37	0.50	--	.05	.18	0.50	10-32	0.62	.18	7/16-20	--	10-32	0.75	0.00	10-32	1.00	0.43	M11SD	M14S	M15SD
3/4"	2.21	2.68	.50	0.50	.12	.06	--	--	1/8 NPT	+	.25	5/8-18	.21	1/4-28	0.96	0.00	----	1.00	0.62	M21	M24S	M25
7/8"	2.31	2.56	.50	0.50	.12	.09	--	--	1/8 NPT	0.93	.25	5/8-18	.21	1/4-28	0.96	0.00	----	1.00	0.62	M21	M24S	M25
1 1/16"	2.56	2.56	.50	0.50	.25	.09	--	--	1/8 NPT	1.12	.31	5/8-18	.25	5/16-24	1.06	0.00*	----	1.00	0.62	M21	M24	M25
1 1/4"	3.34	2.81	.62	0.75	.25	.09	--	--	1/8 NPT	1.34	.43	3/4-16	.37	7/16-20	1.18	0.25	----	1.00	0.75	M61S	M64S	M45
1 1/2"	3.18	3.00	.62	1.25	.25	.09	.25	0.87	1/8 NPT	1.56	.43	3/4-16	.37	7/16-20	1.25	0.25	1/8 NPT	1.00	0.75	M61S	M64S	M45
1 3/4"	4.00	3.00	.75	0.87	.25	.09	.25	1.25	1/4 NPT	1.84	.50	1-14	.43	1/2-20	1.62	0.31	1/4 NPT	1.00	1.03	M71S	M94S	M65
2"	☆	☆	.81	0.87	.37	.10	.25	1.25	1/4 NPT	2.09	.62	1 1/4-12	.56	1/2-20	1.50	0.37	1/4 NPT	☆	1.37	M81S	M94	M85

- N  
O  
T  
E  
S
- ▼ 5/16" Bore Front Head is .50" square, 0.62" diameter across corners, Rear Head O.D. = 0.43" diameter.
  - 7/16" Bore Front Head Dia. = .74", Rear Head Dia. = 0.48"
  - + 3/4" Bore Front Head Dia. = .86", Rear Head Dia. = 0.81"
  - \* Specify Option No. 1 to increase rod extension an additional 1/8"; thread length remains 0.50.
  - ☆ See chart above for 2" bore length dimensions.

## REVERSE ACTING: Universal Mount

### Universal Mount

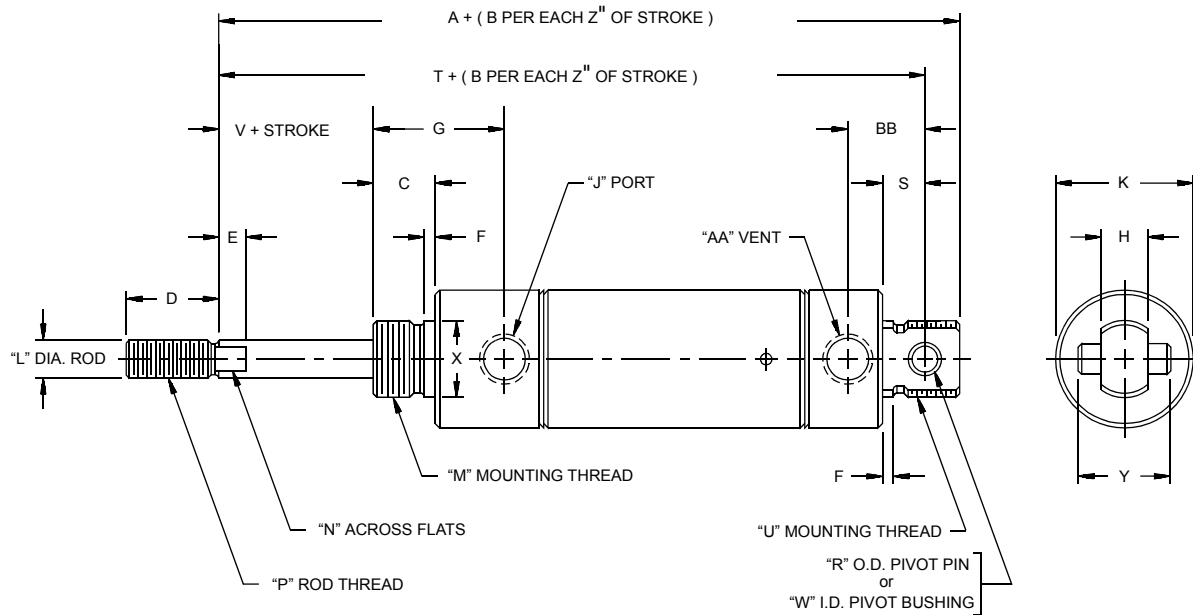

### 2\"/>

2\"/>		
Stroke	A + (B per Z\"/>	
0.50	7.48	7.04
1.00	8.48	8.04
1.50	10.48	10.04

2\"/>		
Stroke	A + (B per Z\"/>	
2.00	11.48	11.04
3.00	13.71	13.28
4.00	17.71	17.28

## Stainless Body Series - Model RVS - Reverse Acting Universal Mount

Bore	Dimension																								
	A	B	C	D	E	F	G	H	J	K	L	M	N	P	R	S	T	U	V	W	X	Y	Z	AA	BB
5/16"	2.03	1.25	.31	0.37	--	.03	0.46	.25	10-32	▼	.12	3/8-24	--	5-40	--	.18	1.87	3/8-24	0.00	.12	0.37	--	0.50	10-32	0.34
7/16"	2.62	1.43	.37	0.50	--	.05	0.71	.31	10-32	0.74	.18	7/16-20	--	10-32	.15	.25	2.37	7/16-20	0.00	--	0.43	0.50	0.50	10-32	0.43
9/16"	2.46	2.62	.37	0.50	--	.05	0.75	.31	10-32	0.62	.18	7/16-20	--	10-32	.15	.25	2.28	7/16-20	0.00	--	0.43	0.50	1.00	10-32	0.43
3/4"	2.71	2.68	.50	0.50	.12	.06	0.96	.37	1/8 NPT	+	.25	5/8-18	.21	1/4-28	.25	.34	2.43	5/8-18	0.00	--	0.62	0.75	1.00	----	--
7/8"	2.90	2.56	.50	0.50	.12	.09	0.96	.37	1/8 NPT	0.93	.25	5/8-18	.21	1/4-28	.25	.34	2.62	5/8-18	0.00	--	0.62	0.75	1.00	----	--
1 1/16"	2.93	2.81	.50	0.50	.25	.09	1.06	.37	1/8 NPT	1.12	.31	5/8-18	.25	5/16-24	.25	.34	2.65	5/8-18	0.00*	--	0.62	0.75	1.00	----	--
1 1/4"	4.15	2.81	.62	0.75	.25	.09	1.18	.50	1/8 NPT	1.34	.43	3/4-16	.37	7/16-20	.25	.43	3.78	3/4-16	0.25	--	0.75	0.87	1.00	----	--
1 1/2"	4.25	3.00	.62	1.25	.25	.09	1.25	.62	1/8 NPT	1.56	.43	3/4-16	.37	7/16-20	.37	.50	3.87	◆	0.25	--	0.75	1.00	1.00	1/8 NPT	0.81
1 3/4"	5.56	3.00	.75	0.87	.25	.09	1.62	.62	1/4 NPT	1.84	.50	1-14	.43	1/2-20	--	.50	5.06	1-14	0.31	.37	1.03	--	1.00	1/4 NPT	1.12
2"	☆	☆	.81	0.87	.37	.10	1.50	.75	1/4 NPT	2.09	.62	1 1/4-12	.56	1/2-20	--	.56	☆	1 1/4-12	0.37	.37	1.37	--	☆	1/4 NPT	0.93

- N  
 O  
 T  
 E  
 S  
 ▼ 5/16" Bore Front Head is .50" square, 0.62" diameter across corners, Rear Head O.D. = 0.43" diameter.  
 + 3/4" Bore Front Head Dia. = .86", Rear Head Dia. = 0.81"  
 \* Specify Option No. 1 to increase rod extension an additional 1/8"; thread length remains 0.50.  
 ◆ 1.00" Dia. Unthreaded, specify Option No. 3 for 3/4-16 UNF x 5/8 long unmilled, threaded rear mounting stud.  
 ☆ See chart above for 2" bore length dimensions.

## REVERSE ACTING: Block Front Mount, Block Front Trunnion Mount

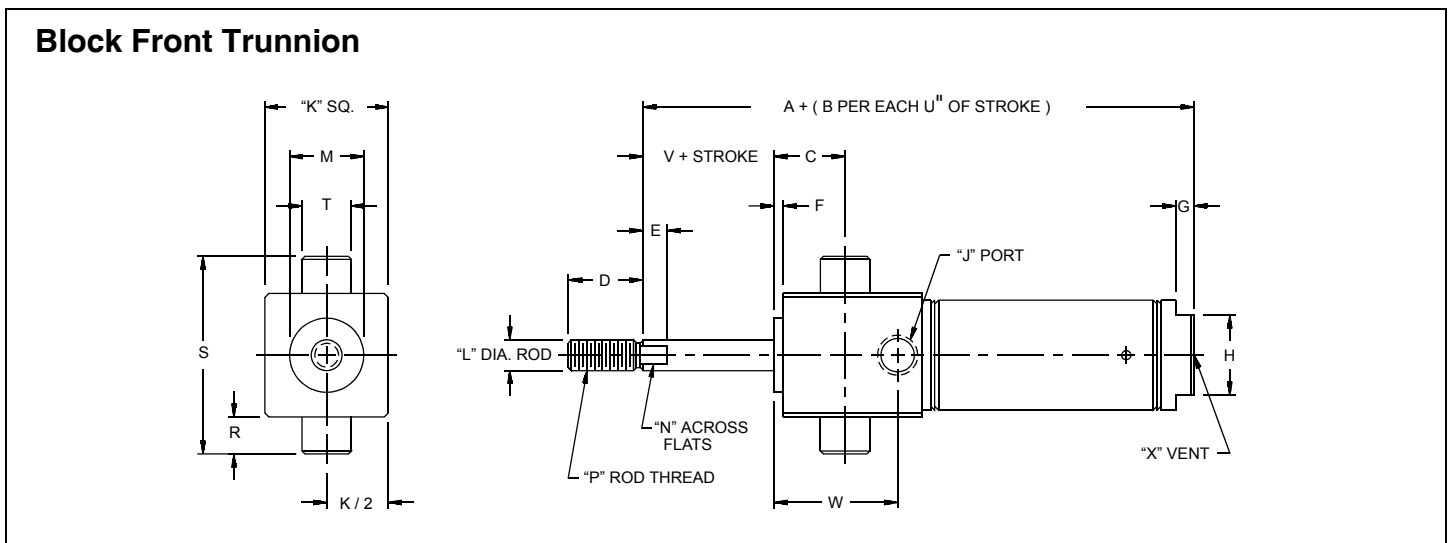
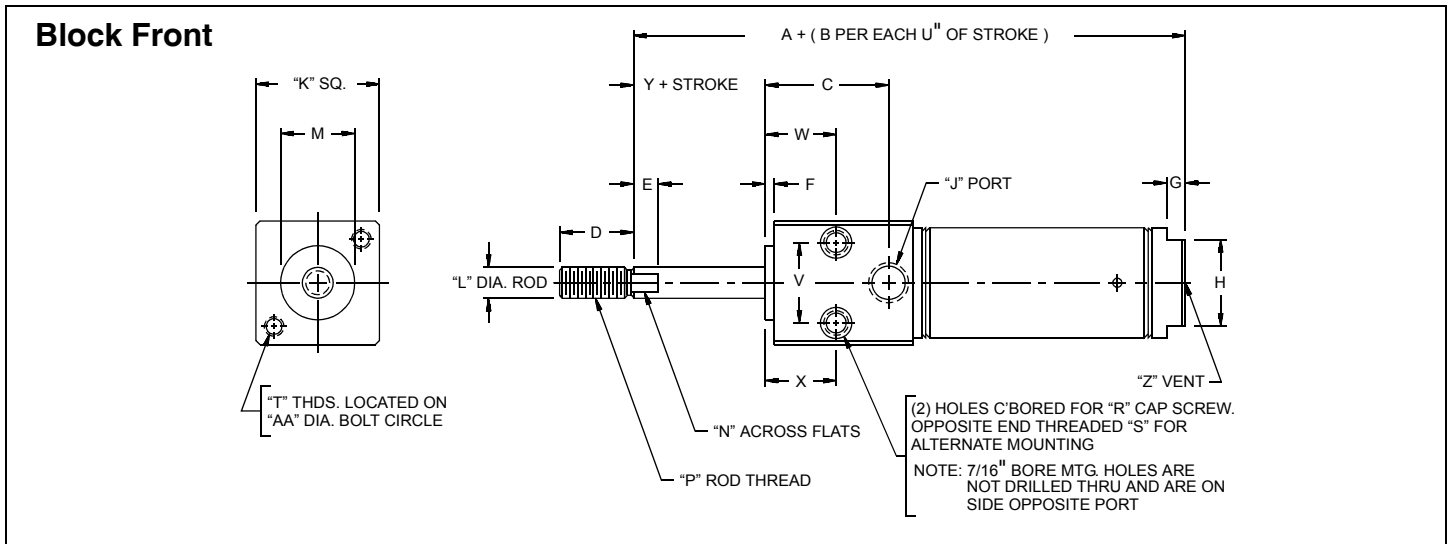

### Stainless Body Series - Model RBFS - Reverse Acting Block Front Mount

Dimension																								
Bore	A	B	C	D	E	F	G	H	J	K	L	M	N	P	R	S	T	U	V	W	X	Y	Z	AA
7/16"	1.81	1.43	0.75	0.50	--	.06	--	--	10-32	0.75	.18	0.43	--	10-32	--	--	8-32	0.50	0.43	0.31	0.75	.00	--	0.75
3/4"	2.46	2.68	0.96	0.75	.25	.09	--	--	1/8 NPT	1.00	.25	0.62	.21	1/4-28	#10	1/4-20	10-32	1.00	0.62	0.46	0.46	.25	--	1.00
1 1/16"	3.28	2.81	1.25	0.75	.25	.09	.18	.87	1/8 NPT	1.25	.31	0.75	.25	5/16-24	#10	1/4-20	10-32	1.00	0.81	0.71	0.71	.37	1/8 NPT	1.25
1 1/2"	4.00	2.68	1.65	1.25	.25	.12	.25	.87	1/4 NPT	1.75	.43	1.00	.37	7/16-20	1/4"	5/16-18	1/4-20	1.00	1.12	1.00	1.00	.25	1/4 NPT	1.75

### Stainless Body Series - Model RBFTS - Reverse Acting Block Front Trunnion Mount

Dimension																				Mounting Accessory		
Bore	A	B	C	D	E	F	G	H	J	K	L	M	N	P	R	S	T	U	V	W	X	Bkt. No.
7/16"	1.81	1.43	.31	.50	--	.06	--	--	10-32	0.75	.18	0.43	--	10-32	.25	1.25	.37	0.50	.00	0.75	--	M17S
3/4"	2.46	2.68	.43	.75	.25	.09	--	--	1/8 NPT	1.00	.25	0.62	.21	1/4-28	.37	1.75	.50	1.00	.25	0.96	--	M37S
1 1/16"	3.28	2.81	.71	.75	.25	.09	.18	.87	1/8 NPT	1.25	.31	0.75	.25	5/16-24	.37	2.00	.50	1.00	.37	1.25	1/8 NPT	M37S
1 1/2"	4.00	2.68	1.06	1.25	.25	.12	.25	.87	1/4 NPT	1.75	.43	1.00	.37	7/16-20	.37	2.50	.50	1.00	.25	1.65	1/4 NPT	M37S

## REVERSE ACTING: Block Rear Mount, Block Rear Trunnion Mount

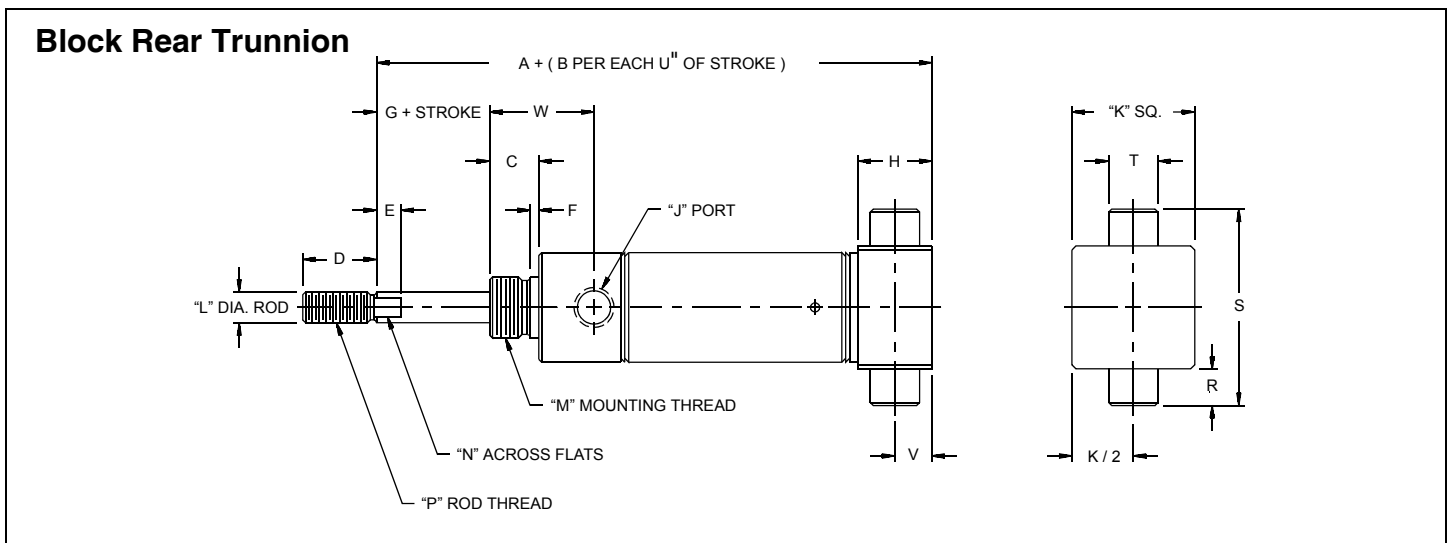
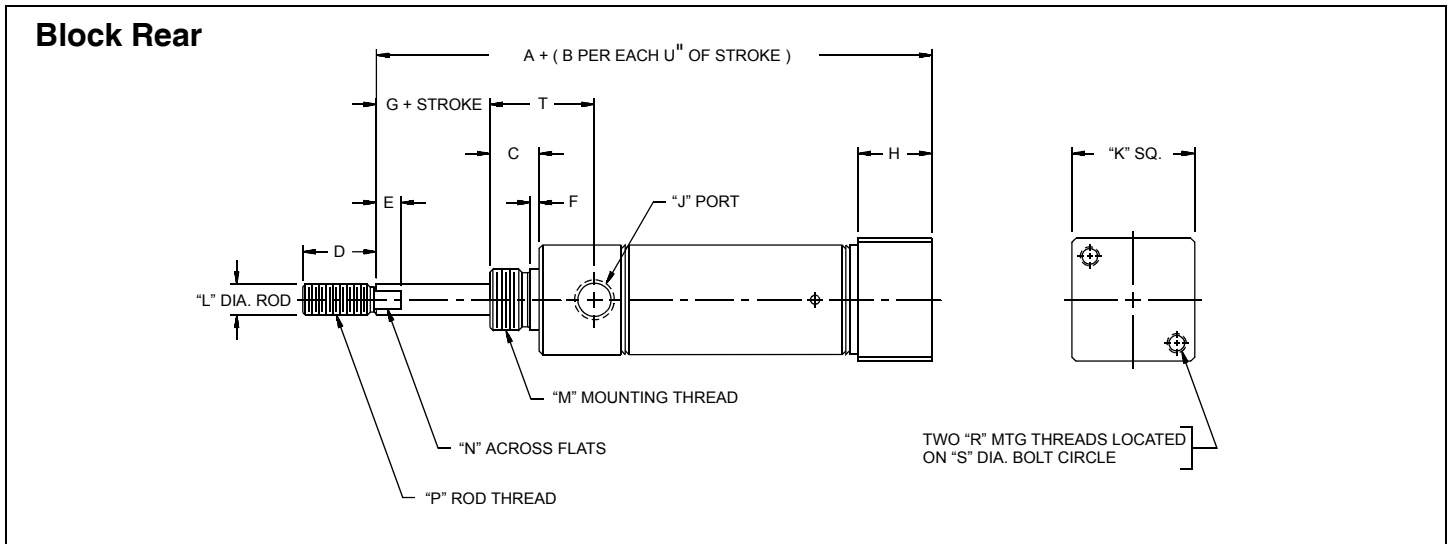

### Stainless Body Series - Model RBRS - Reverse Acting Block Rear Mount

Bore	Dimension																	
	A	B	C	D	E	F	G	H	J	K	L	M	N	P	R	S	T	U
7/16"	2.25	1.43	.37	0.50	--	.05	.00	.50	10-32	0.75	.18	7/16-20	--	10-32	8-32	0.75	0.71	0.50
3/4"	3.21	2.68	.50	0.75	.25	.06	.25	.75	1/8 NPT	1.00	.25	5/8-18	.21	1/4-28	10-32	1.00	0.96	1.00
1 1/16"	3.53	2.81	.50	0.75	.25	.09	.37	.75	1/8 NPT	1.25	.31	5/8-18	.25	5/16-24	10-32	1.25	1.06	1.00
1 1/2"	3.87	3.00	.62	1.25	.25	.09	.25	1.00	1/4 NPT	1.75	.43	3/4-16	.37	7/16-20	1/4-20	1.75	1.21	1.00

### Stainless Body Series - Model RBRTS - Reverse Acting Block Rear Trunnion Mount

Bore	Dimension																		Mounting Accessory	
	A	B	C	D	E	F	G	H	J	K	L	M	N	P	R	S	T	V	W	Bkt. No.
7/16"	2.25	1.43	.37	0.50	--	.05	.00	0.50	10-32	0.75	.18	7/16-20	--	10-32	.25	1.25	.37	.25	0.71	M17S
3/4"	3.21	2.68	.50	0.75	.25	.06	.25	0.75	1/8 NPT	1.00	.25	5/8-18	.21	1/4-28	.37	1.75	.50	.37	0.96	M37S
1 1/16"	3.53	2.81	.50	0.75	.25	.09	.37	0.75	1/8 NPT	1.25	.31	5/8-18	.25	5/16-24	.37	2.00	.50	.37	1.06	M37S
1 1/2"	3.87	3.00	.62	1.25	.25	.09	.25	1.00	1/4 NPT	1.75	.43	3/4-16	.37	7/16-20	.37	2.50	.50	.50	1.21	M37S



# MOUNTING ACCESSORIES: Dimensional Data

## Foot Bracket

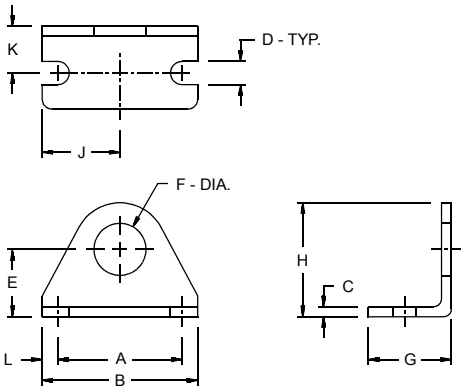

Bore	Foot Bkt. No.	Dimension										
		A	B	C	D	E	F	G	H	J	K	L
5/16" S.A.	M01SS	0.75	1.00	.06	.13	.43	.25	.37	.75	.50	.25	.12
5/16"	M01SD	0.75	1.00	.06	.13	.43	.37	.37	.75	.50	.25	.12
7/16" S.A.	M11SS	1.00	1.37	.07	.18	.56	.37	.62	.87	.68	.31	.18
7/16"	M11SD	1.00	1.37	.07	.18	.56	.43	.62	.93	.68	.31	.18
9/16"	M11SD	1.00	1.37	.07	.18	.56	.43	.62	.93	.68	.31	.18
3/4" S.A.	M21SS	1.25	1.62	.10	.18	.68	.50	.75	1.09	.81	.43	.18
3/4"	M21	1.50	1.87	.12	.28	.81	.62	1.00	1.37	.93	.56	.18
7/8"	M21	1.50	1.87	.12	.28	.81	.62	1.00	1.37	.93	.56	.18
1 1/16"	M21	1.50	1.87	.12	.28	.81	.62	1.00	1.37	.93	.56	.18
1 1/4"	M61S	1.87	2.50	.15	.28	1.00	.75	1.50	1.75	1.25	.75	.31
1 1/2"	M61S	1.87	2.50	.15	.28	1.00	.75	1.50	1.75	1.25	.75	.31
1 3/4"	M71S	2.25	3.00	.18	.34	1.25	1.03	1.50	2.12	1.50	.87	.37
2"	M81S	2.25	3.12	.25	.34	1.50	1.37	1.62	2.56	1.56	1.00	.43
3"	M101S	3.50	4.37	.25	.34	1.89	1.62	1.62	3.14	2.18	1.00	.43

Note: One mounting nut is provided with each foot bracket ordered.

## Mounting Nut

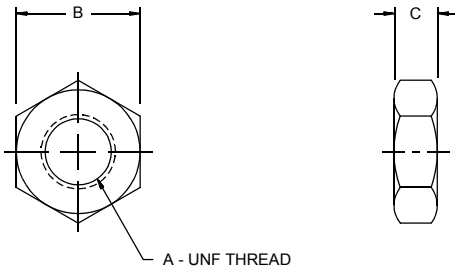

Bore	Mtg. Nut No.	Dimension		
		A	B	C
5/16" S.A.	M05SS	1/4-28	.43	.15
5/16"	M15SS	3/8-24	.56	.21
7/16" S.A.	M15SS	3/8-24	.56	.21
7/16"	M15SD	7/16-20	.68	.25
9/16"	M15SD	7/16-20	.68	.25
3/4" S.A.	M25SS	1/2-20	.74	.31
3/4"	M25	5/8-18	.93	.37
7/8"	M25	5/8-18	.93	.37
1 1/16"	M25	5/8-18	.93	.37
1 1/4"	M45	3/4-16	1.12	.42
1 1/2"	M45	3/4-16	1.12	.42
1 3/4"	M65	1-14	1.50	.54
2"	M85	1 1/4-12	1.87	.54
3"	M105S	1 1/2-12	2.25	.50

## Rod Clevis

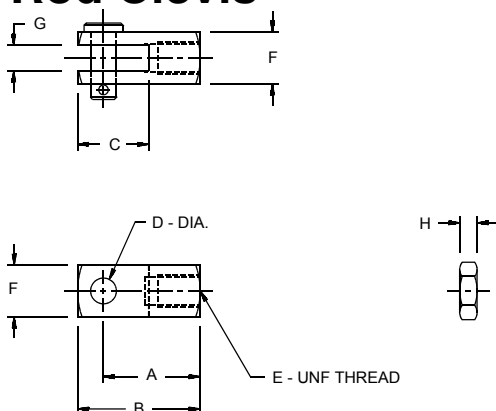

Bore	Rod Clevis No.	Dimension							
		A	B	C	D	E	F	G	H
5/16"	M04S	.43	.56	.37	.12	5-40	.31	.13	.10
7/16"	M14S	.75	.93	.56	.18	10-32	.37	.18	.12
9/16"	M14S	.75	.93	.56	.18	10-32	.37	.18	.12
3/4"	M24S	.93	1.18	.68	.25	1/4-28	.50	.25	.15
7/8"	M24S	.93	1.18	.68	.25	1/4-28	.50	.25	.15
1 1/16"	M24	.93	1.18	.68	.25	5/16-24	.50	.25	.18
1 1/4"	M64S	1.31	1.68	.93	.37	7/16-20	.75	.37	.25
1 1/2"	M64S	1.31	1.68	.93	.37	7/16-20	.75	.37	.25
1 3/4"	M94	1.31	1.68	.93	.37	1/2-20	.75	.37	.31
2"	M94	1.31	1.68	.93	.37	1/2-20	.75	.37	.31
3"	M104S	2.25	2.75	1.50	.50	5/8-18	1.00	.50	.37

Note: Rod nut and pin are provided with each rod clevis ordered.

## MOUNTING ACCESSORIES: Dimensional Data (Continued)

### Pivot / Trunnion Bracket

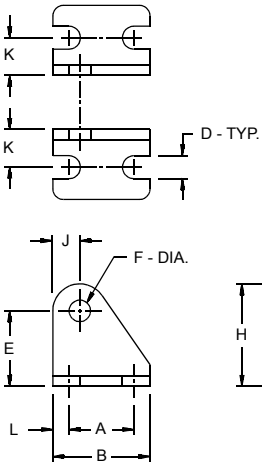

### Pivot Bracket - Style I

Bore	Pivot Bkt. No.	Dimension										
		A	B	C	D	E	F	G	H	J	K	L
7/16"	M13S	.50	.75	.06	.18	.56	.15	.50	.77	.20	.28	.12
9/16"	M13S	.50	.75	.06	.18	.56	.15	.50	.77	.20	.28	.12
3/4"	M23S	.75	1.12	.12	.26	.87	.25	.81	1.18	.31	.43	.18
7/8"	M23S	.75	1.12	.12	.26	.87	.25	.81	1.18	.31	.43	.18
1 1/16"	M23S	.75	1.12	.12	.26	.87	.25	.81	1.18	.31	.43	.18
1 1/4"	M23S	.75	1.12	.12	.26	.87	.25	.81	1.18	.31	.43	.18
1 1/2"	M63S	1.00	1.50	.12	.26	1.37	.37	1.00	1.75	.37	.62	.25

### Trunnion Bracket

Bore	Trunnion Bkt. No.	Dimension										
		A	B	C	D	E	F	G	H	J	K	L
7/16"	M17S	1.00	1.50	.25	.34	1.37	.37	1.12	1.75	.37	.68	.25
3/4"	M37S	1.00	1.50	.25	.34	1.37	.50	1.12	1.75	.37	.68	.25
1 1/16"	M37S	1.00	1.50	.25	.34	1.37	.50	1.12	1.75	.37	.68	.25
1 1/2"	M37S	1.00	1.50	.25	.34	1.37	.50	1.12	1.75	.37	.68	.25

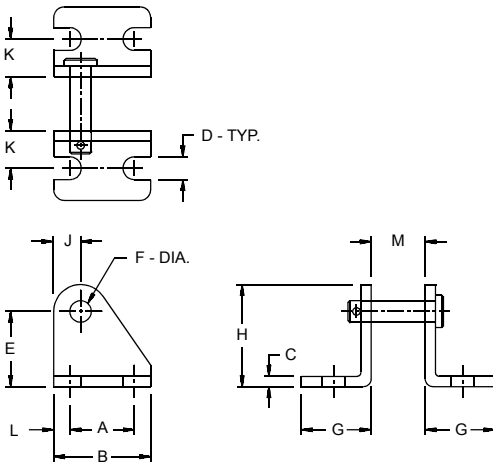

### Pivot Bracket - Style II

Bore	Pivot Bkt. No.	Dimension											
		A	B	C	D	E	F	G	H	J	K	L	M
7/16"	M13SP	.50	.75	.06	.18	.56	.15	.50	.77	.20	.28	.12	.31
9/16"	M13SP	.50	.75	.06	.18	.56	.15	.50	.77	.20	.28	.12	.31
3/4"	M23SP	.75	1.12	.12	.26	.87	.25	.81	1.18	.31	.43	.18	.37
7/8"	M23SP	.75	1.12	.12	.26	.87	.25	.81	1.18	.31	.43	.18	.37
1 1/16"	M23SP	.75	1.12	.12	.26	.87	.25	.81	1.18	.31	.43	.18	.37
1 1/4"	M53SP	.75	1.12	.12	.26	.87	.25	.81	1.18	.31	.43	.18	.50
1 1/2"	M63SP	1.00	1.50	.12	.26	1.37	.37	1.00	1.75	.37	.62	.25	.62
1 3/4"	M73SP	1.00	1.50	.25	.34	1.37	.37	1.12	1.75	.37	.68	.25	.62
2"	M93	1.00	1.50	.25	.34	1.37	.37	1.12	1.75	.37	.68	.25	.75
3"	M103SP	1.25	1.75	.25	.26	1.75	.50	1.50	2.25	.50	.87	.25	.87

NOTES

- Style II Brackets are only for models having the (-2) Pivot Bushing Option.
- Pivot Pin & Cotter Pin included with each Style II Bracket ordered.

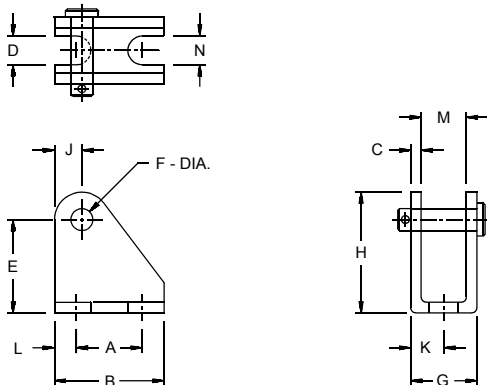

### Pivot Bracket - Style III

Bore	Pivot Bkt. No.	Dimension												
		A	B	C	D	E	F	G	H	J	K	L	M	N
5/16"	M03SP	.37	.62	.04	15*	.40	.12	.36	.53	.12	.18	.12	.26	.15*
3/4"	M33S	.75	1.18	.12	.26	.87	.25	.62	1.18	.31	.31	.21	.38	.26
7/8"	M33S	.75	1.18	.12	.26	.87	.25	.62	1.18	.31	.31	.21	.38	.26
1 1/16"	M33S	.75	1.18	.12	.26	.87	.25	.62	1.18	.31	.31	.21	.38	.26
1 1/4"	M53S	.75	1.25	.12	.32	1.06	.25	.76	1.37	.31	.37	.25	.51	.32*

NOTES

- Style III Brackets are only for models having the (-2) Pivot Bushing Option.
- Pivot Pin & Cotter Pin included with each Style III Bracket ordered.
- \* These are thru hole diameters, not slots as shown.



---

## American Cylinder Co., Inc.

---

**American Cylinder Co., Inc.**  
Peotone, Illinois 60468-9116  
708/258-3935  
FAX 708/258-3980

### ON THE INTERNET

<http://www.americancylinder.com>

<http://www.ameristore.biz>

E-MAIL: [amcyl@americancylinder.com](mailto:amcyl@americancylinder.com)

## Warranty

American Cylinder Co., Inc. warrants its products to be free from defects in material and workmanship under normal wear and service for a period of 3 years from date of shipment of the order. American Cylinder Company shall have no liability under this warranty if: 1) The product is used other than in accordance with specifications. 2) The product is subjected to abuse, negligence, accident, misapplication, or unintended use. 3) The product is manufactured to buyer's specifications.

Manufacturer's liability shall be limited to allowance of credit or replacement of defective product. American Cylinder Company shall not be liable or responsible for injuries or damages to persons or property arising out of the use or operation of American Cylinder products.

THIS WARRANTY IS EXPRESSLY IN LIEU OF ALL OTHER WARRANTIES, EXPRESSED OR IMPLIED, INCLUDING ANY IMPLIED WARRANTY OF MERCHANTABILITY OR FITNESS FOR A PARTICULAR PURPOSE, LIABILITY FOR LOST PROFIT OR FOR INDIRECT, INCIDENTAL, CONSEQUENTIAL OR COMMERCIAL LOSSES, AND OF ALL OTHER OBLIGATIONS OR LIABILITIES.

These conditions subject to change without notice.