

 **American**<sup>®</sup>

**Magnetic Field Cylinders**  
**Reed Switches and Solid State Switches**

**Stainless Steel Body Air Cylinders**  
**Hard Coated Aluminum Body Air Cylinders**



**MFC**<sup>®</sup>

**Magnetic Field Cylinders**  
**Standard Catalog**  
**9/16 inch through**  
**2-1/2 inch bore**

**American Cylinder Co., Inc.**

## TABLE OF CONTENTS

Table of Contents .....	Page 1	<b>Double Acting Models</b>	
<b>MFC® Air Cylinders: Option 4</b> .....	Page 1	Stainless Body: Universal Mount.....	Page 8
<b>Standard Features and Benefits</b> .....	Page 2	Aluminum Body: Universal Mount .....	Page 8
<b>How to Order</b> .....	Page 3	<b>Double Acting Models</b>	
<b>Standard Stroke Lengths</b> .....	Page 4	Stainless Body: Block Front .....	Page 9
<b>Single Acting Models</b>		Stainless Body: Block Front Trunnion .....	Page 9
Stainless Body: Nose Mount.....	Page 5	<b>Double Acting Models</b>	
Stainless Body: Universal Mount .....	Page 5	Stainless Body: Block Rear .....	Page 10
<b>Double Acting Models</b>		Stainless Body: Block Rear Trunnion.....	Page 10
Stainless Body: Double End Rod.....	Page 6	<b>Optional Sensing Switch</b> .....	Page 11 & 12
Aluminum Body: Double End Rod.....	Page 6	<b>Switch Part Numbers</b> .....	Page 13
<b>Double Acting Models</b>		<b>Mounting Accessories</b>	
Stainless Body: Nose Mount.....	Page 7	Dimensional Data .....	Page 14 & 15
Aluminum Body: Nose Mount.....	Page 7	<b>Warranty</b> .....	Page 16

---

## AMERICAN MFC® AIR CYLINDERS

American's MFC® Air Cylinders are designed to operate American's Reed or Solid State Switches and are available in 9/16", 3/4", 1-1/16", 1-1/4", 1-1/2", 1-3/4" and 2" bores in the Stainless Steel Series and in 1-1/8", 1-1/2", 2" and 2-1/2" bores in the thick walled hardcoated Aluminum 76 Series.

American's Magnetic Field Cylinders provide the same reliability and design features as American's standard line of cylinders. The option 4 specification adds a magnet to the reciprocating piston assembly. The magnet's unique design provides a magnetic flux field to trigger the actuation of the American Reed Switch or Solid State Switch when passing the switch's detection zone.

Specifying the MFC option (Option No. 4) does not change the overall envelope dimensions or the mounting dimensions of American Cylinder's standard Double Acting catalog models. This feature simplifies the process of updating and converting existing equipment design to incorporate Reed or Solid State Switch technology.

Additional design choices are provided by American Cylinder offering Single Acting Spring Return Magnetic Field Cylinders as a standard catalog item. The Single Acting MFC models maintain all the features of the standard line Single Acting models except for a moderate increase in overall length.

Greater flexibility is offered by American Cylinder's original mounting band design which provides a low profile while allowing infinite adjustability 360° along the complete useful length of cylinder stroke.

Standard catalog options such as Bumpers and Fluoroelastomer Seals are readily available. For more involved special requirements, special stroke lengths or other modifications, consult your American Cylinder Distributor or the factory.

Refer to the "How to Order" section on page 3 for details on ordering MFC Air Cylinders.

---

Product enhancements resulting from our quality improvement program may necessitate changes in specifications without notice.

American Cylinder Distributors are located in every major industrial market.

## STANDARD FEATURES AND BENEFITS

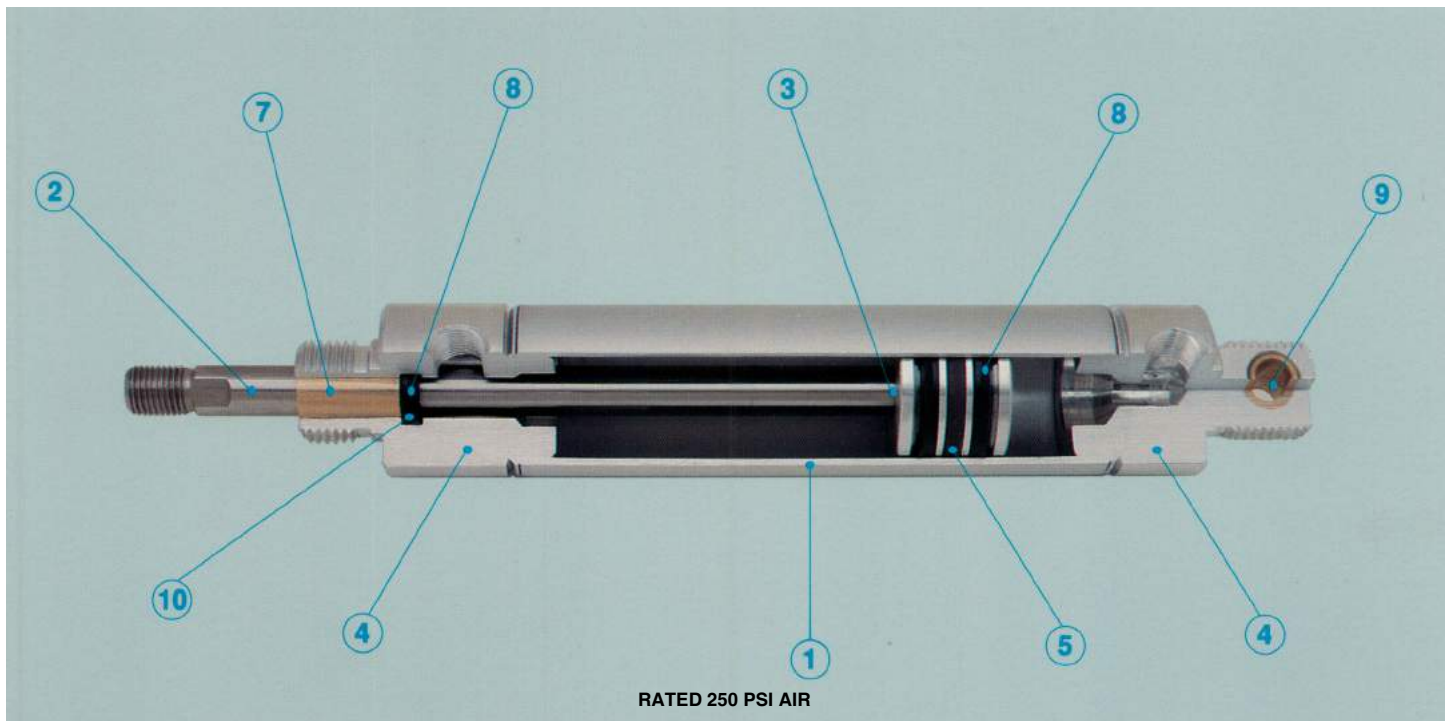

### ① Cylinder Body

**Stainless Steel:** Type 304 Stainless Steel manufactured to special mill specifications and tolerances to insure a long cylinder life.

**Aluminum 76 Series:** Thick wall hardcoated aluminum tubing exhibits excellent wear and seizure resistance while providing additional impact protection.

② **Stainless Steel Rod:** Ground & Polished Type 303 Stainless Steel rods are standard on both the Stainless Steel Series and the Aluminum 76 Series. All rods have wrench flats and stress relief grooves (9/16" bore excluded).

③ **Piston Rod Assembly:** Piston rods are threaded, anaerobically sealed, and machine staked into the piston for triple protection.

④ **End Caps, Piston:** High strength aluminum alloy.

⑤ **Magnet for Sensing Switch Actuation:** Internal magnet specially designed for use with American Reed or Solid State switches.

⑥ **Springs:** Springs for spring action cylinders are made from music wire and designed for millions of cycles. Special spring forces are available.

⑦ **Rod Guide Bushing:** Standard on all models. The oil impregnated sintered bronze bushing increases the life of the cylinder rod and provides a non-abrasive bearing surface.

⑧ **Buna-N U-Cup Rod & Piston Seals:** U-Cup seals provide low breakaway friction and maximize cylinder life expectancy. Standard Buna-N seals are recommended for operating temperatures of -20°F (-25°C) to 200°F (95°C). Fluoroelastomer seals are available for higher temperature applications.

⑨ **Pivot Pin/Pivot Bushing:** Stainless Steel Series cylinders are shipped with plated steel pivot pins as standard. (1 3/4" & 2" bores supplied with pivot bushing only.) Sintered bronze pivot bushings are available as an alternative standard option. Aluminum 76 Series models all utilize the oil impregnated sintered bronze bushing as standard.

⑩ **Rod Seal:** Precision machined rod seal groove provides a smooth sealing surface while positively retaining the seal without requiring additional components and relying on press fit containment.

⑪ **Prelubricated:** All cylinders are factory lubricated with a special high endurance oil mixture.

⑫ **Pre-Tested:** The quality of each cylinder is assured by testing each unit for leakage prior to shipment. Quality control provides added value to American cylinders.

Product enhancements resulting from our quality improvement program may necessitate changes in specifications without notice.

# HOW TO ORDER:

**Example:** 1 1/16" Bore Double Acting Universal Mount Magnetic Field Cylinder  
2" Stroke - Bumpers - Ports Rotated 90°

**Model No.:** 1062DVS-2.00-4-32-33

**Model No.**

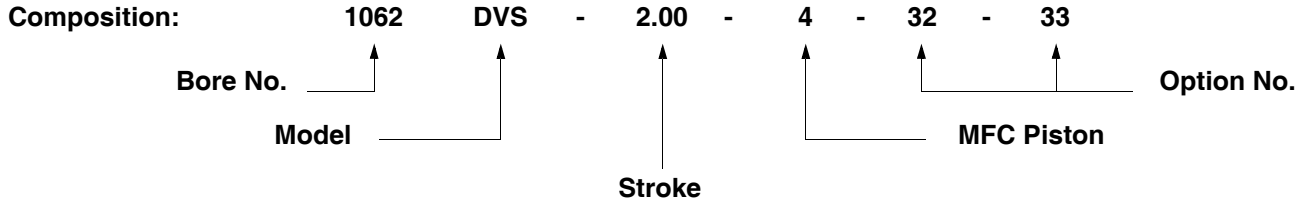

Bore	No.	Model Description	Model	MFC Piston	Standard Options	No.
9/16"	562	Stainless Single Acting Nose Mount	SNS	4	1/8" Additional Rod Extension	1 <sup>a</sup>
3/4"	750	Stainless Single Acting Universal Mount	SVS		Rear Pivot Bushing (Omit Pin)	2
1 1/16"	1062	Stainless Double Acting Nose Mount	DNS		Unmilled Threaded Rear Mtg. Stud	3 <sup>b</sup>
1 1/8"	1125	Stainless Double Acting Universal Mount	DVS		Quad-XWiper/Seal	5
1 1/4"	1250	Aluminum Double Acting Nose Mount	DN		Magnalube	6
1 1/2"	1500	Aluminum Double Acting Universal Mount	DV		Fluoroelastomer Seals	31
1 3/4"	1750	Stainless Double Acting Block Front	DBFS		Bumpers	32 <sup>c</sup>
2"	2000	Stainless Double Acting Block Front Trunnion	DBFTS		Ports Rotated 90°	33
2 1/2"	2500	Stainless Double Acting Block Rear	DBRS			
		Stainless Double Acting Block Rear Trunnion	DBRTS			
		Stainless Double End Rod	DES			
		Aluminum Double End Rod	DE			

- N  
O  
T  
E  
S
- a 1 1/16" bore only.
  - b Reduces tang length by .250 on the 1 1/2" bore models. Same thread as nose thread.
  - c See page 4 for Bumper Length Adder.

Product enhancements resulting from our quality improvement program may necessitate changes in specifications without notice.

American Cylinder Distributors are located in every major industrial market.

# STANDARD STROKE LENGTHS

## Stainless Body Series

### Models SNS & SVS - Page 5

Bore	Standard Stroke Lengths (in.)	Bumper (-32) Length Adder	Power Factor
9/16"	1/2, 1, 1 1/2, 2, 3, 4	.062	.25
3/4"	1/2, 1, 1 1/2, 2, 3, 4	.125	.44
1 1/16"	1/2, 1, 1 1/2, 2, 3, 4	.000	.89
1 1/4"	1/2, 1, 1 1/2, 2, 3, 4	-.125	1.23
1 1/2"	1/2, 1, 1 1/2, 2, 3, 4	.125	1.77

### Models DNS & DVS - Pages 7 & 8

Bore	Standard Stroke Lengths (in.)	Bumper (-32) Length Adder	Power Factor	
			Push	Pull
9/16"	1/2, 1, 1 1/2, 2, 3, 4	.125	.25	.22
3/4"	1/2, 1, 1 1/2, 2, 3, 4, 5, 6, 8, 10, 12	.250	.44	.39
1 1/16"	1/2, 1, 1 1/2, 2, 3, 4, 5, 6, 8, 10, 12	.125	.89	.81
1 1/4"	1/2, 1, 1 1/2, 2, 3, 4, 5, 6, 8, 10, 12	.000	1.23	1.07
1 1/2"	1/2, 1, 1 1/2, 2, 3, 4, 5, 6, 8, 10, 12, 14, 16, 18	.250	1.77	1.62
1 3/4"	1/2, 1, 1 1/2, 2, 3, 4, 5, 6, 8, 10, 12, 14, 16, 18	.000	2.40	2.20
2"	1/2, 1, 1 1/2, 2, 2 1/2, 3, 4, 5, 6, 7, 8, 9, 10, 11, 12, 14, 16, 18, 20, 22, 24	.250	3.14	2.83

NOTE: Stroke lengths in blue only apply to DVS models.

### Model DES - Page 6

Bore	Standard Stroke Lengths (in.)	Bumper (-32) Length Adder	Power Factor
9/16"	1/2, 1, 1 1/2, 2, 3, 4	.125	.22
3/4"	1/2, 1, 1 1/2, 2, 3, 4, 5, 6, 8, 10, 12	.250	.39
1 1/16"	1/2, 1, 1 1/2, 2, 3, 4, 5, 6, 8, 10, 12	.125	.81
1 1/4"	1/2, 1, 1 1/2, 2, 3, 4, 5, 6, 8, 10, 12	.000	1.07
1 1/2"	1/2, 1, 1 1/2, 2, 3, 4, 5, 6, 8, 10, 12	.250	1.62
1 3/4"	1/2, 1, 1 1/2, 2, 3, 4, 5, 6, 8, 10, 12	.000	2.20
2"	1/2, 1, 1 1/2, 2, 2 1/2, 3, 4, 5, 6, 7, 8, 9, 10, 11, 12	.250	2.83

### Models DBFS, DBFTS, DBRS & DBRTS - Pages 9 & 10

Bore	Standard Stroke Lengths (in.)	Bumper (-32) Length Adder	Power Factor	
			Push	Pull
3/4"	1/2, 1, 1 1/2, 2, 3, 4, 5, 6	.250	.44	.39
1 1/16"	1/2, 1, 1 1/2, 2, 3, 4, 5, 6	.125	.89	.81
1 1/2"	1/2, 1, 1 1/2, 2, 3, 4, 5, 6	.250	1.77	1.62

## Aluminum Body Series

### Model DN & DV - Page 7 & 8

Bore	Standard Stroke Lengths (in.)	Bumper (-32) Length Adder	Power Factor	
			Push	Pull
1 1/8"	1/2, 1, 1 1/2, 2, 3, 4, 5, 6, 8, 10, 12	.250	.99	.88
1 1/2"	1/2, 1, 1 1/2, 2, 3, 4, 5, 6, 8, 10, 12, 14, 16, 18	.000	1.77	1.57
2"	1/2, 1, 1 1/2, 2, 3, 4, 5, 6, 7, 8, 9, 10, 11, 12, 14, 16, 18, 20, 22, 24	.000	3.14	2.83
2 1/2"	1/2, 1, 1 1/2, 2, 3, 4, 5, 6, 7, 8, 9, 10, 11, 12, 14, 16, 18, 20, 22, 24	.000	4.91	4.60

NOTE: Stroke lengths in blue only apply to DV models

### Model DE - Page 6

Bore	Standard Stroke Lengths (in.)	Bumper (-32) Length Adder	Power Factor
2 1/2"	1/2, 1, 1 1/2, 2, 3, 4, 5, 6, 7, 8, 9, 10, 11, 12	.000	4.60

• Consult factory for special stroke lengths.

• Cylinder Output Force = Power Factor x Air Line Pressure

## SINGLE ACTING: Nose Mount, Universal Mount

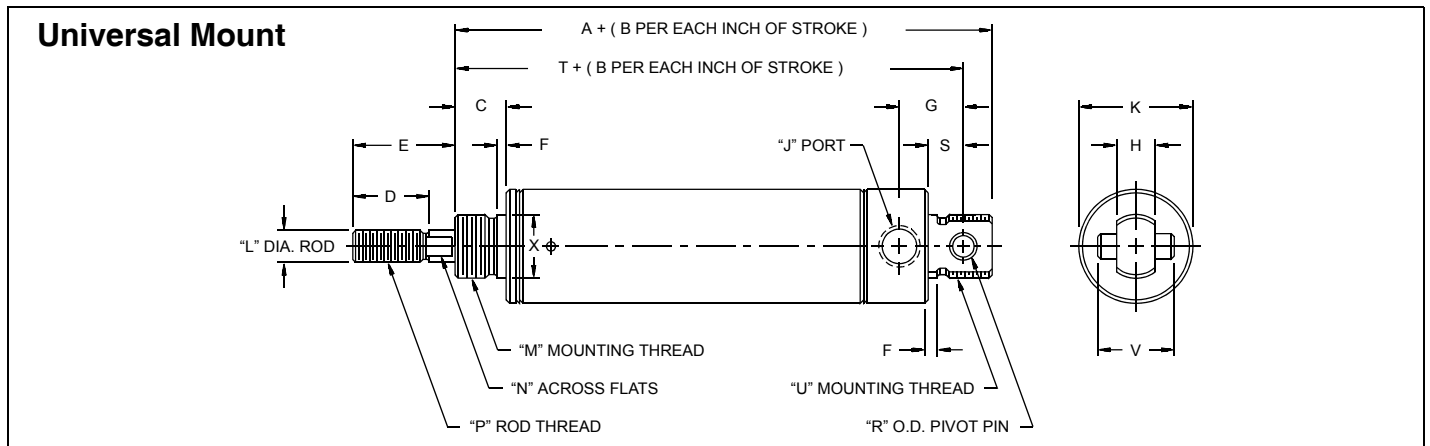
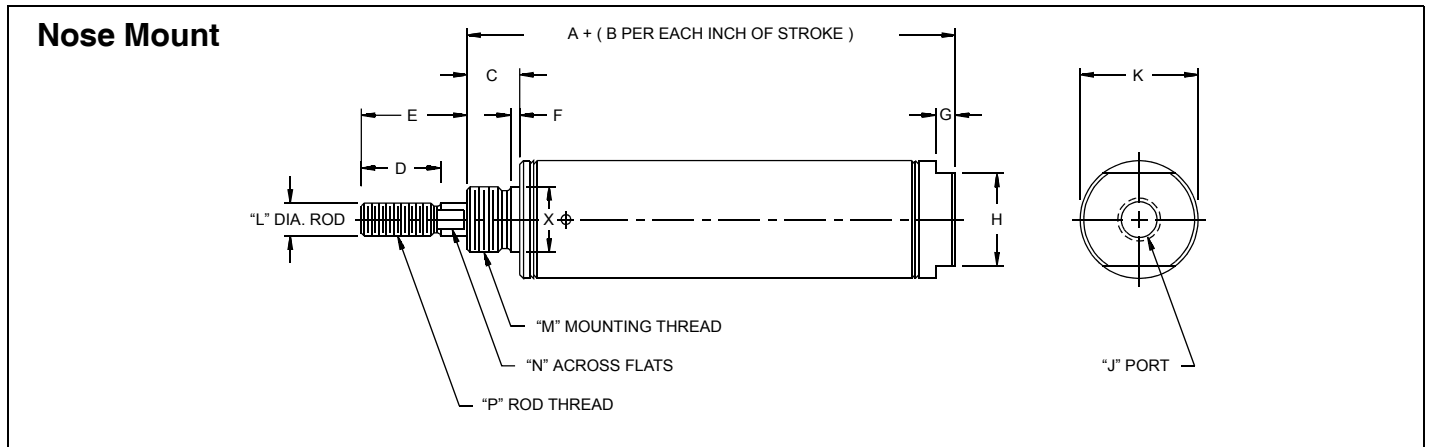

### Stainless Body Series - Model SNS - Single Acting Nose Mount

Bore	Dimension															Spring Forces		Mounting Accessories	
	A	B	C	D	E	F	G	H	J	K	L	M	N	P	X	Rod Ret.	Rod Ext.	Foot Bkt.	Mtg. Nut
9/16"	1.75	1.62	.37	.50	.50	.05	.18	.50	10-32	.62	.18	7/16-20	--	10-32	.43	2	4	M11SD	M15SD
3/4"	2.12	1.68	.43	.50	.50	.05	.18	.62	1/8 NPT	.81	.25	1/2-20	.21	1/4-28	.50	3	6	M21SS	M25SS
1 1/16"	2.37	1.56	.50	.50	.50*	.06	.18	.87	1/8 NPT	1.12	.31	5/8-18	.25	5/16-24	.62	3	6	M21	M25
1 1/4"	3.00	1.81	.62	.75	1.00	.09	.18	.87	1/8 NPT	1.34	.43	3/4-16	.37	7/16-20	.75	7 1/2	15	M61S	M45
1 1/2"	2.62	1.68	.62	.75	1.00	.09	.25	.87	1/8 NPT	1.56	.43	3/4-16	.37	7/16-20	.75	6	12	M61S	M45

\*Specify Option no. 1 to increase rod extension an additional 1/8"; thread length remains 0.50.

### Stainless Body Series - Model SVS - Single Acting Universal Mount

Bore	Dimension																	Mounting Accessories					
	A	B	C	D	E	F	G	H	J	K	L	M	N	P	R	S	T	U	V	X	Foot Bkt.	Pivot Bkt.	Rod Clevis
9/16"	2.28	1.62	.37	.50	.50	.05	.43	.31	10-32	.62	.18	7/16-20	--	10-32	.15	.25	2.09	7/16-20	.50	.43	M11SD	M13S	M14S
3/4"	3.18	1.68	.43	.50	.50	.05	.62	.37	1/8 NPT	.86	.25	1/2-20	.21	1/4-28	.25	.34	2.90	5/8-18	.75	.62	M21SS	M23S	M24S
1 1/16"	3.25	1.56	.50	.50	.50*	.06	.62	.37	1/8 NPT	1.12	.31	5/8-18	.25	5/16-24	.25	.34	2.96	5/8-18	.75	.62	M21	M23S	M24
1 1/4"	4.12	1.81	.62	.75	1.00	.09	.71	.50	1/8 NPT	1.34	.43	3/4-16	.37	7/16-20	.25	.40	3.71	3/4-16	.87	.75	M61S	M23S	M64S
1 1/2"	3.68	1.68	.62	.75	1.00	.09	.81	.62	1/8 NPT	1.56	.43	3/4-16	.37	7/16-20	.37	.50	3.31	(f)	1.00	.75	M61S	M63S	M64S

\*Specify Option no. 1 to increase rod extension an additional 1/8"; thread length remains 0.50.

f 1.00" diameter unthreaded; specify Option no. 3 for unmilled, threaded rear mounting stud, overall length reduces 0.25".

## DOUBLE ACTING: Double End Rod

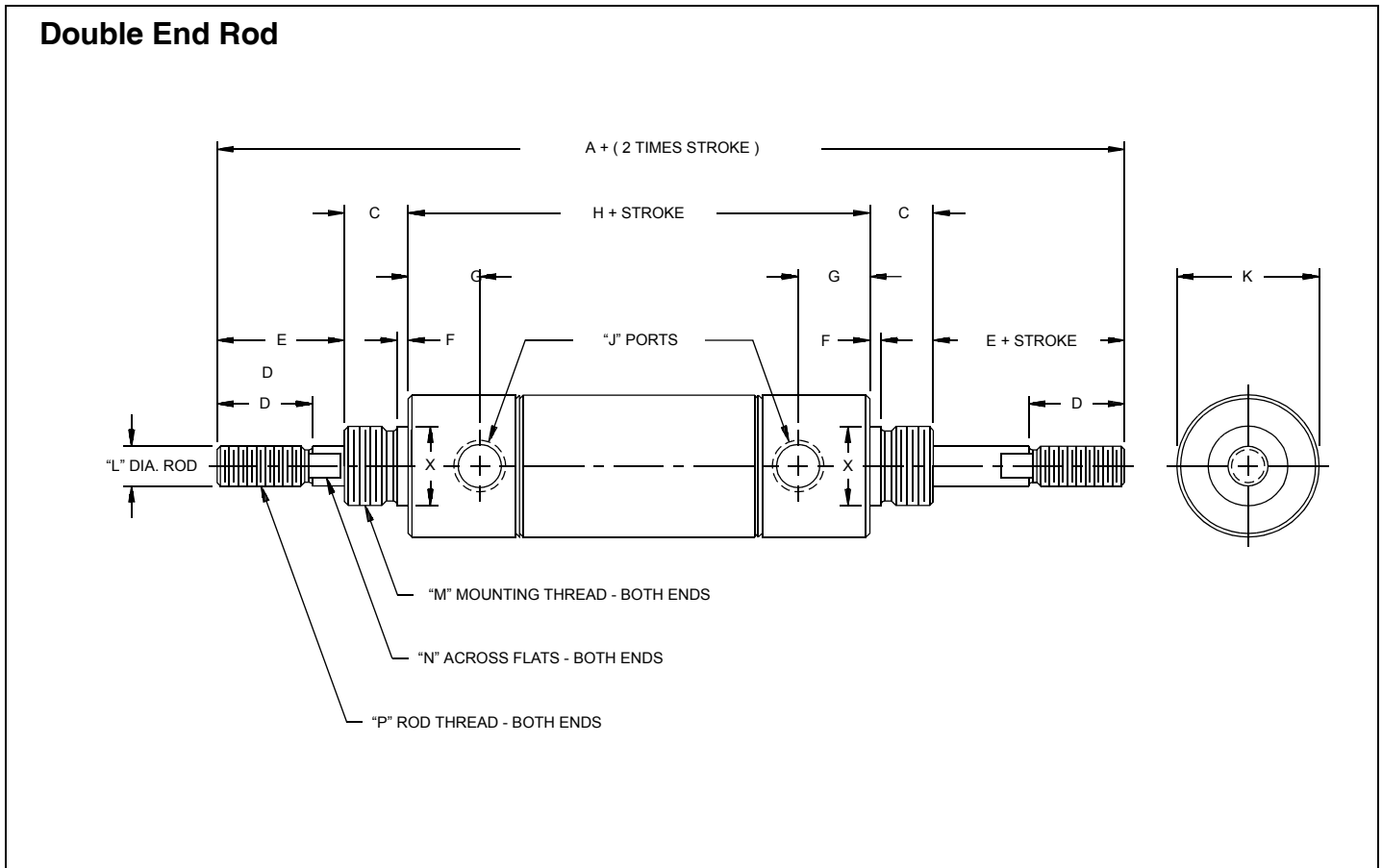

### Stainless Body Series - Model DES - Double End Rod

Bore	Dimension														Mounting Accessories		
	A	C	D	E	F	G	H	J	K	L	M	N	P	X	Foot Bkt.	Rod Clevis	Mtg. Nut
9/16"	3.93	.37	.50	.50	.05	.37	2.18	10-32	.62	.18	7/16-20	--	10-32	.43	M11SD	M14S	M15SD
3/4"	5.00	.50	.50	.50	.06	.46	3.00	1/8 NPT	.86	.25	5/8-18	.21	1/4-28	.62	M21	M24S	M25
1 1/16"	5.37	.50	.50	.62	.09	.56	3.12	1/8 NPT	1.12	.31	5/8-18	.25	5/16-24	.62	M21	M24	M25
1 1/4"	7.06	.62	.75	1.00	.09	.56	3.81	1/8 NPT	1.34	.43	3/4-16	.37	7/16-20	.75	M61S	M64S	M45
1 1/2"	6.62	.62	.75	1.00	.09	.62	3.37	1/8 NPT	1.56	.43	3/4-16	.37	7/16-20	.75	M61S	M64S	M45
1 3/4"	8.31	.75	.87	1.18	.09	.87	4.43	1/4 NPT	1.84	.50	1-14	.43	1/2-20	1.03	M71S	M94	M65
2"	8.31	.81	.87	1.25	.10	.68	4.18	1/4 NPT	2.09	.62	1 1/4-12	.56	1/2-20	1.37	M81S	M94	M85

### Aluminum 76 Body Series - Model DE - Double End Rod

Bore	Dimension														Mounting Accessories		
	A	C	D	E	F	G	H	J	K	L	M	N	P	X	Foot Bkt.	Rod Clevis	Mtg. Nut
2 1/2"	8.31	.81	.87	1.25	.12	.68	4.18	1/4 NPT	2.73	.62	1 3/8-12	.56	1/2-20	1.50	M91	M94	M95

## DOUBLE ACTING: Nose Mount

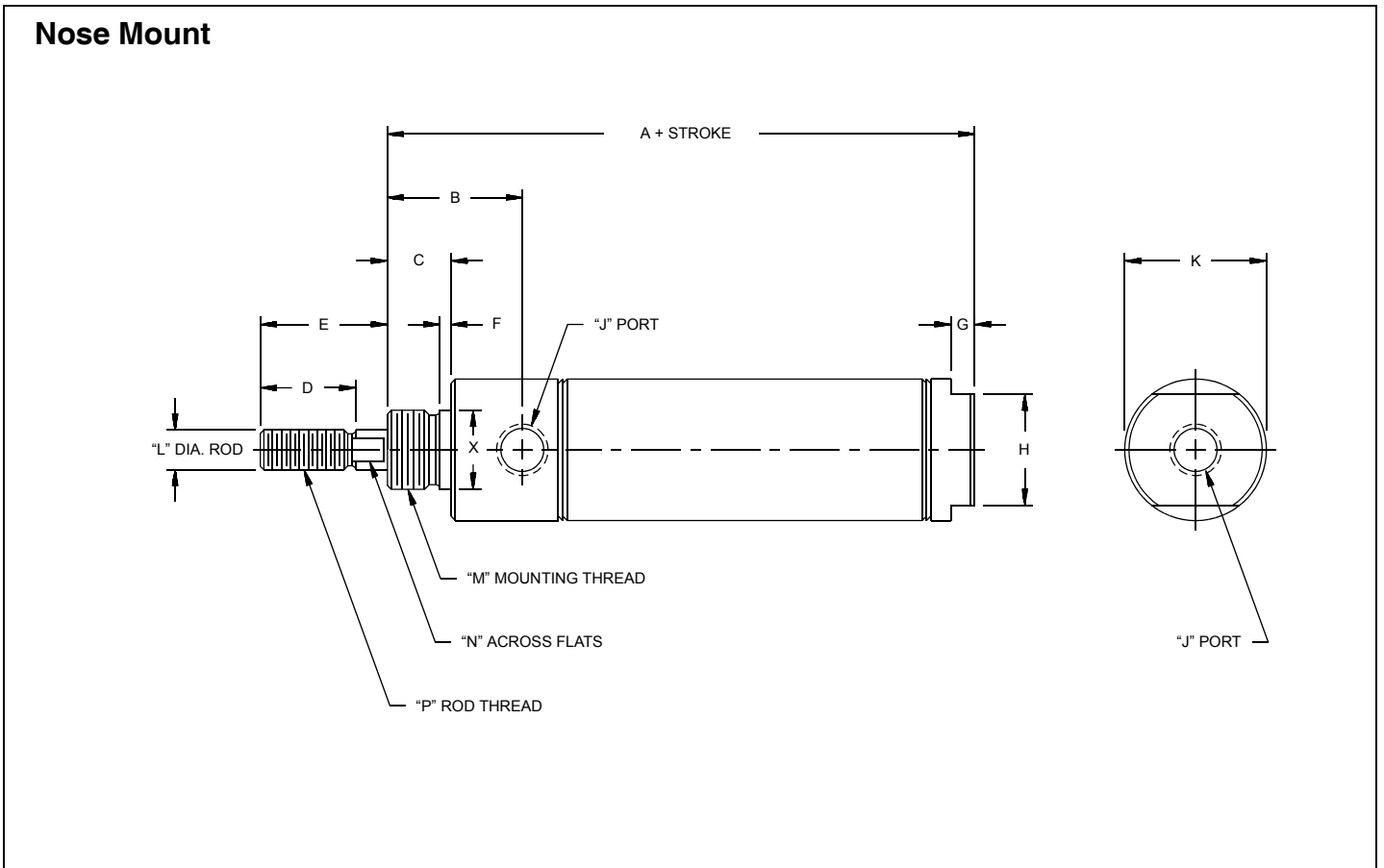

### Stainless Body Series - Model DNS - Double Acting Nose Mount

Dimension																	Mounting Accessories		
Bore	A	B	C	D	E	F	G	H	J	K	L	M	N	P	X	Foot Bkt.	Rod Clevis	Mtg. Nut	
9/16"	2.21	.75	.37	.50	.50	.05	.18	.50	10-32	.62	.18	7/16-20	--	10-32	.43	M11SD	M14S	M15SD	
3/4"	2.96	.96	.50	.50	.50	.06	.18	.62	1/8 NPT	.86	.25	5/8-18	.21	1/4-28	.62	M21	M24S	M25	
1 1/16"	3.12	1.06	.50	.50	.50*	.09	.18	.87	1/8 NPT	1.12	.31	5/8-18	.25	5/16-24	.62	M21	M24	M25	
1 1/4"	3.75	1.18	.62	.75	1.00	.09	.18	.87	1/8 NPT	1.34	.43	3/4-16	.37	7/16-20	.75	M61S	M64S	M45	
1 1/2"	3.43	1.25	.62	.75	1.00	.09	.25	.87	1/8 NPT	1.56	.43	3/4-16	.37	7/16-20	.75	M61S	M64S	M45	
1 3/4"	4.37	1.62	.75	.87	1.18	.09	.25	1.25	1/4 NPT	1.84	.50	1-14	.43	1/2-20	1.03	M71S	M94	M65	
2"	4.31	1.50	.81	.87	1.25	.10	.25	1.25	1/4 NPT	2.09	.62	1 1/4-12	.56	1/2-20	1.37	M81S	M94	M85	

\*Specify Option no. 1 to increase rod extension an additional 1/8"; thread length remains 0.50.

### Aluminum Body 76 Series- Model DN - Double Acting Nose Mount

Dimension																	Mounting Accessories			
Bore	A	B	C	D	E	F	G	H	J	K	L	M	N	P	X	Foot Bkt.	Flange	Rod Clevis	Mtg. Nut	
1 1/8"	3.37	1.18	.62	.50	.75	.09	.18	.87	1/8 NPT	1.28	.37	3/4-16	.31	3/8-24	.75	M41	M42	M44	M45	
1 1/2"	4.12	1.37	.75	.75	1.00	.09	.25	1.00	1/4 NPT	1.71	.50	1-14	.43	1/2-20	1.00	M61	M62	M64	M65	
2"	4.62	1.62	.87	.87	1.25	.10	.25	1.25	1/4 NPT	2.23	.62	1 1/4-12	.56	5/8-18	1.25	M81	M82	M84	M85	
2 1/2"	4.31	1.50	.81	.87	1.25	.12	.25	1.50	1/4 NPT	2.73	.62	1 3/8-12	.56	1/2-20	1.50	M91	--	M94	M95	



## DOUBLE ACTING: Universal Mount

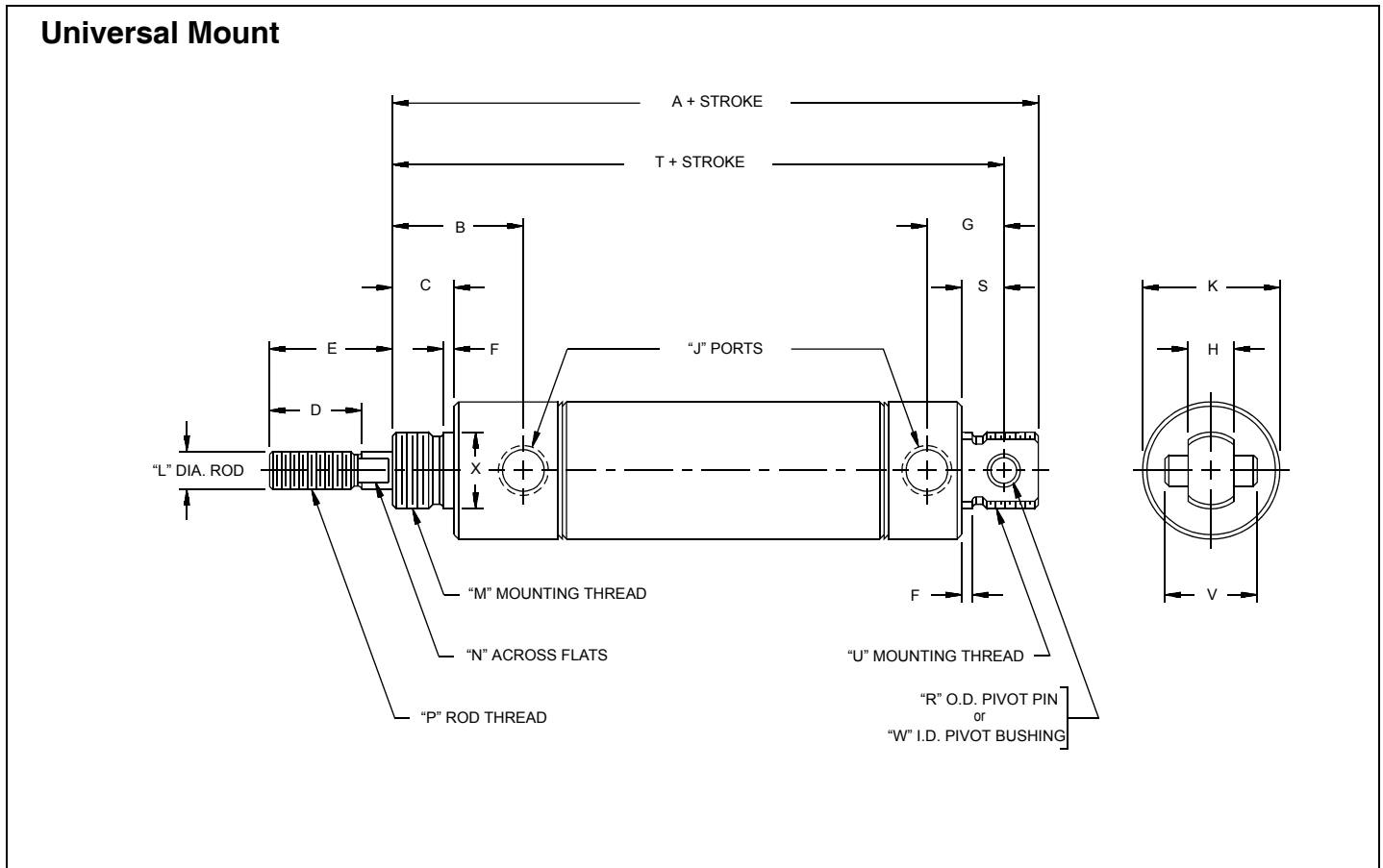

### Stainless Body Series - Model DVS - Double Acting Universal Mount

Bore	Dimension																			Mounting Accessories				
	A	B	C	D	E	F	G	H	J	K	L	M	N	P	R	S	T	U	V	W	X	Foot Bkt.	Pivot Bkt.	Rod Clevis
9/16"	2.75	.75	.37	.50	.50	.05	.43	.31	10-32	.62	.18	7/16-20	--	10-32	.15	.25	2.56	7/16-20	.50	--	.43	M11SD	M13S	M14S
3/4"	4.03	.96	.50	.50	.50	.06	.62	.37	1/8 NPT	.86	.25	5/8-18	.21	1/4-28	.25	.34	3.75	5/8-18	.75	--	.62	M21	M23S	M24S
1 1/16"	4.00	1.06	.50	.50	.50*	.09	.62	.37	1/8 NPT	1.12	.31	5/8-18	.25	5/16-24	.25	.34	3.71	5/8-18	.75	--	.62	M21	M23S	M24
1 1/4"	4.87	1.18	.62	.75	1.00	.09	.71	.50	1/8 NPT	1.34	.43	3/4-16	.37	7/16-20	.25	.40	4.46	3/4-16	.87	--	.75	M61S	M23S	M64S
1 1/2"	4.50	1.25	.62	.75	1.00	.09	.81	.62	1/8 NPT	1.56	.43	3/4-16	.37	7/16-20	.37	.50	4.12	(f)	1.00	--	.75	M61S	M63S	M64S
1 3/4"	5.93	1.62	.75	.87	1.18	.09	1.12	.62	1/4 NPT	1.84	.50	1-14	.43	1/2-20	--	.50	5.43	1-14	---	.37	1.03	M71S	M73SP	M94
2"	5.68	1.50	.81	.87	1.25	.10	.93	.75	1/4 NPT	2.09	.62	1 1/4-12	.56	1/2-20	--	.56	5.25	1 1/4-12	--	.37	1.37	M81S	M93	M94

\*Specify Option no. 1 to increase rod extension an additional 1/8"; thread length remains 0.50.

† 1.00" diameter unthreaded; specify Option no. 3 for unmilled, threaded rear mounting stud, overall length reduces 0.25".

### Aluminum Body 76 Series - Model DV - Double Acting Universal Mount

Bore	Dimension																			Mounting Accessories				
	A	B	C	D	E	F	G	H	J	K	L	M	N	P	S	T	U	W	X	Foot Bkt.	Flange	Pivot Bkt.	Rod Clevis	Mtg. Nut
1 1/8"	4.50	1.18	.62	.50	.75	.09	.81	.50	1/8 NPT	1.28	.37	3/4-16	.31	3/8-24	.50	4.18	3/4-16	.25	.75	M41	M42	M43	M44	M45
1 1/2"	5.62	1.37	.75	.75	1.00	.09	1.09	.75	1/4 NPT	1.71	.50	1-14	.43	1/2-20	.71	5.21	1-14	.31	1.00	M61	M62	M63	M64	M65
2"	6.12	1.62	.87	.87	1.25	.10	1.09	.75	1/4 NPT	2.23	.62	1 1/4-12	.56	5/8-18	.71	5.71	1 1/4-12	.31	1.25	M81	M82	M83	M84	M85
2 1/2"	5.68	1.50	.81	.87	1.25	.12	.93	.75	1/4 NPT	2.73	.62	1 3/8-12	.56	1/2-20	.56	5.25	1 3/8-12	.37	1.50	M91	--	M93	M94	M95

## DOUBLE ACTING: Block Front Mount, Block Front Trunnion Mount

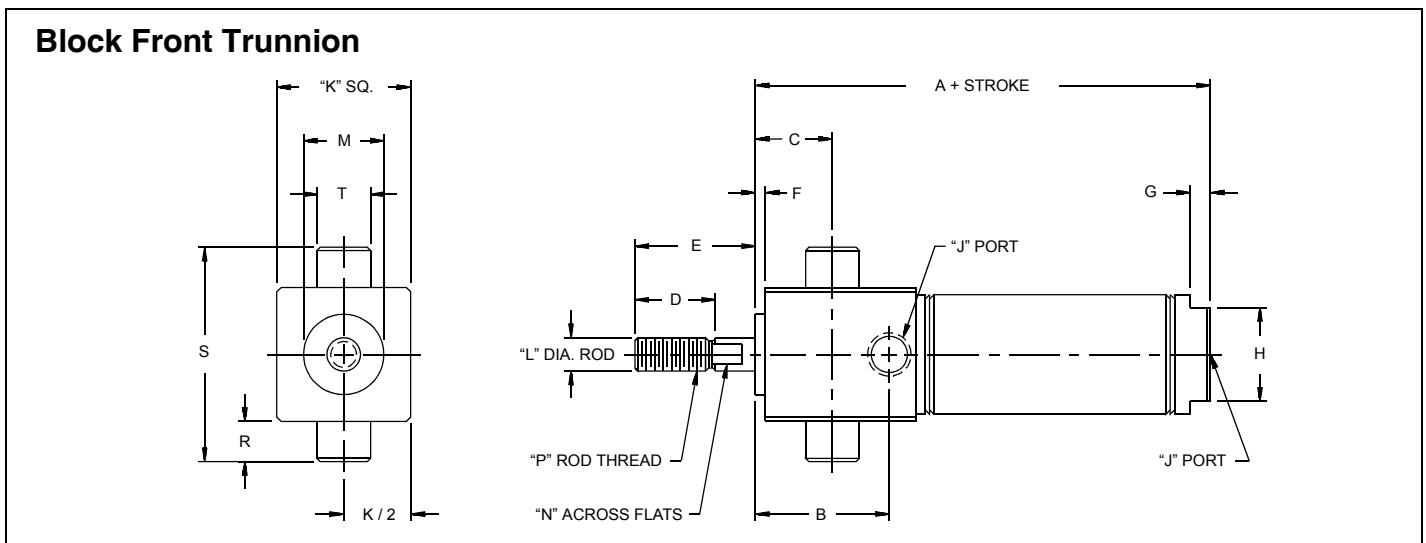
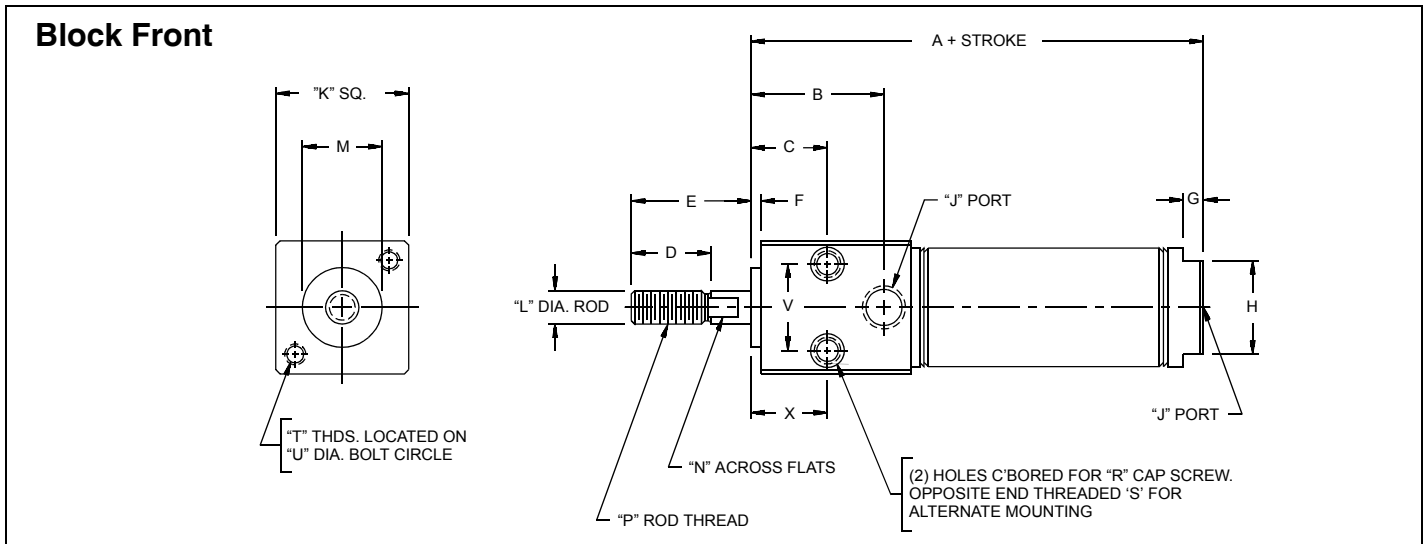

### Stainless Body Series - Model DBFS - Double Acting Block Front Mount

Bore	Dimension																			
	A	B	C	D	E	F	G	H	J	K	L	M	N	P	R	S	T	U	V	X
3/4"	2.96	.96	.46	.75	1.00	.09	.18	.62	1/8NPT	1.00	.25	.62	.21	1/4-28	#10	1/4-20	10-32	1.00	.62	.46
1 1/16"	3.37	1.25	.71	.75	1.12	.09	.18	.87	1/8NPT	1.25	.31	.75	.25	5/16-24	#10	1/4-20	10-32	1.25	.81	.71
1 1/2"	3.93	1.65	1.00	1.25	1.50	.12	.25	.87	1/4NPT	1.75	.43	1.00	.37	7/16-20	1/4"	5/16-18	1/4-20	1.75	1.12	1.00

### Stainless Body Series - Model DBFTS - Double Acting Block Front Trunnion Mount

Bore	Dimension																			Mounting Accessory
	A	B	C	D	E	F	G	H	J	K	L	M	N	P	R	S	T	Bkt.No.		
3/4"	2.96	.96	.43	.75	1.00	.09	.18	.62	1/8NPT	1.00	.25	.62	.21	1/4-28	.37	1.75	.50	M37S		
1 1/16"	3.37	1.25	.71	.75	1.12	.09	.18	.87	1/8NPT	1.25	.31	.75	.25	5/16-24	.37	2.00	.50	M37S		
1 1/2"	3.93	1.65	1.06	1.25	1.50	.12	.25	.87	1/4NPT	1.75	.43	1.00	.37	7/16-20	.37	2.50	.50	M37S		

## DOUBLE ACTING: Block Rear Mount, Block Rear Trunnion Mount

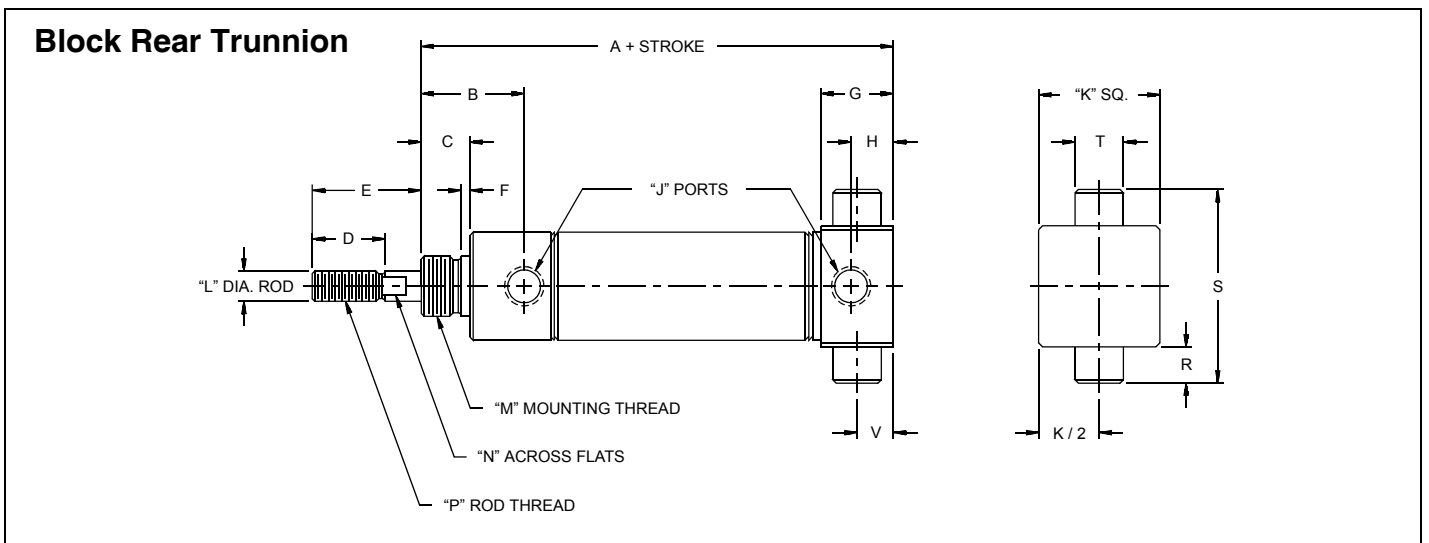
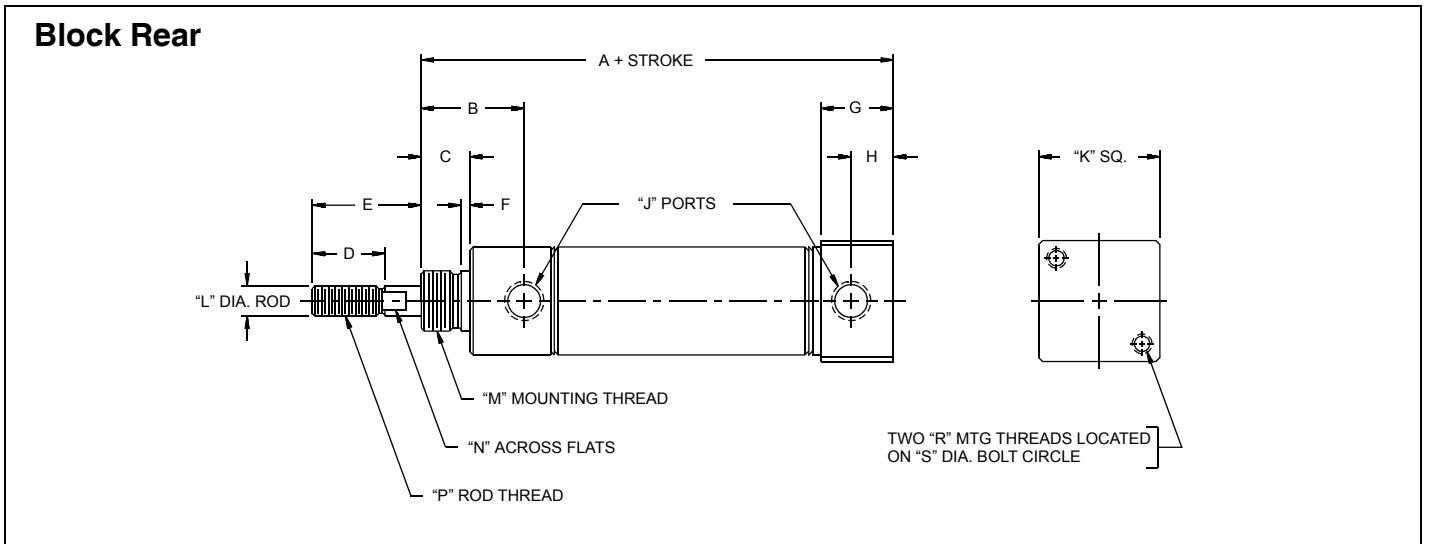

### Stainless Body Series - Model DBRS - Double Acting Block Rear Mount

Bore	Dimension															
	A	B	C	D	E	F	G	H	J	K	L	M	N	P	R	S
3/4"	3.53	.96	.50	.75	1.00	.06	.75	.43	1/8 NPT	1.00	.25	5/8-18	.21	1/4-28	10-32	1.00
1 1/16"	3.62	1.06	.50	.75	1.12	.09	.75	.43	1/8 NPT	1.25	.31	5/8-18	.25	5/16-24	10-32	1.25
1 1/2"	4.12	1.21	.62	1.25	1.50	.09	1.00	.62	1/4 NPT	1.75	.43	3/4-16	.37	7/16-20	1/4-20	1.75

### Stainless Body Series - Model DBRTS - Double Acting Block Rear Trunnion Mount

Bore	Dimension																Mounting Accessory		
	A	B	C	D	E	F	G	H	J	K	L	M	N	P	R	S	T	V	Bkt.No.
3/4"	3.53	.96	.50	.75	1.00	.06	.75	.43	1/8 NPT	1.00	.25	5/8-18	.21	1/4-28	.37	1.75	.50	.37	M37S
1 1/16"	3.62	1.06	.50	.75	1.12	.09	.75	.43	1/8 NPT	1.25	.31	5/8-18	.25	5/16-24	.37	2.00	.50	.37	M37S
1 1/2"	4.12	1.21	.62	1.25	1.50	.09	1.00	.62	1/4 NPT	1.75	.43	3/4-16	.37	7/16-20	.37	2.50	.50	.50	M37S

# OPTIONAL SENSING SWITCHES

All cylinders ordered with the MFC (Option No. 4) can be used in conjunction with Reed or Solid State switches for position sensing. Clamping bands are included with each switch ordered and are pre-sized for easy installation. Switches must be ordered separate from cylinders as an accessory item.

## Reed Switches (AC or DC)

American's Reed Switches can be used on either AC or DC applications and are available with or without an LED indicator. In order to avoid premature contact deterioration, always operate within switch specifications listed below. Switch life can be maximized by implementing protection circuits as indicated.

### SPECIFICATIONS

#### Non-LED Reed Switch

- Switching Logic.....Normally Open
- Contact Type.....Single Pole  
Single Throw
- Contact Rating:

  - Power.....5 Watts
  - Voltage.....1 to 125V (AC or DC)
  - Switching Current.....1mA to 100mA
  - Breakdown Voltage.....250 Volts

- Ambient Temperature.....14°F to 140°F
- Indicator.....None
- Plain End Lead Wire.....39 in.
- Enclosure Rating.....IEC Standard IP67
- DC Polarity.....Pos. (brown)  
Neg. (blue)

AC OPERATION

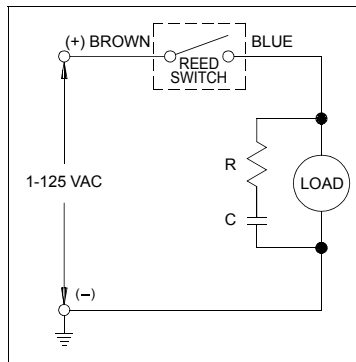

LOAD MUST NOT EXCEED 5 WATT SWITCH RATING  
R = RESISTOR (Under 1k OHM)  
C = CAPACITOR (0.01 Microfarad)

DC OPERATION

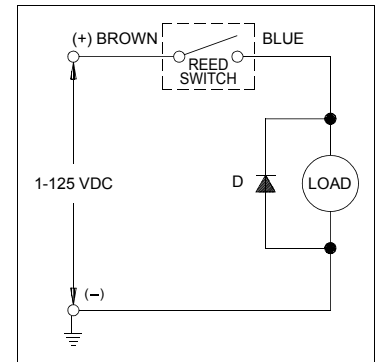

LOAD MUST NOT EXCEED 5 WATT SWITCH RATING  
D = DIODE MATCHED TO LOAD VOLTAGE & CURRENT

#### LED Reed Switch

- Switching Logic.....Normally Open
- Contact Type.....Single Pole  
Single Throw
- Contact Rating:

  - Power.....5 Watts
  - Voltage.....3 to 125V (AC or DC)
  - Switching Current.....10mA to 40mA
  - Breakdown Voltage.....250 Volts

- Ambient Temperature.....14°F to 140°F
- Indicator.....Red LED
- Plain End Lead Wire.....39 in.
- M8 Pigtail Connector.....6 in.
- Enclosure Rating.....IEC Standard IP67
- DC Polarity.....Pos. (brown)  
Neg. (blue)

AC OPERATION

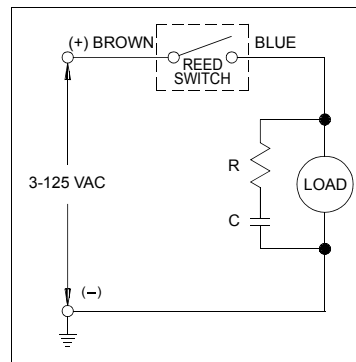

LOAD MUST NOT EXCEED 5 WATT SWITCH RATING  
R = RESISTOR (Under 1k OHM)  
C = CAPACITOR (0.01 Microfarad)

DC OPERATION

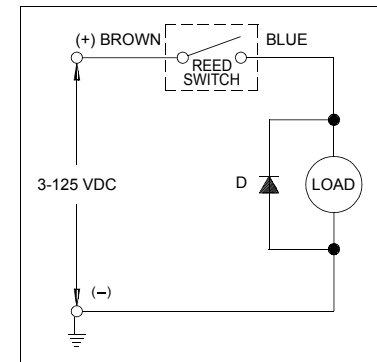

LOAD MUST NOT EXCEED 5 WATT SWITCH RATING  
D = DIODE MATCHED TO LOAD VOLTAGE & CURRENT

### Special Notes:

- All switches are pretested at the manufacturer.
- The use of an ohmmeter is recommended whenever field testing is required. Do not use an incandescent light bulb or any other testing device which may subject the switches to inrush loads beyond their ratings.
- Do not exceed 2.5 in.-lbs. tightening torque on lock nut.
- Use integral circuits as described to maximize Reed Switch life.
- The LED Switches require a minimum current flow of 10mA for LED illumination.
- Polarity must be observed in DC applications.
- Solid State Switches have DC capability only.

## OPTIONAL SENSING SWITCHES (Continued)

### Solid State Switches (DC only)

American's Solid State Switches are designed for DC applications only. With no mechanical parts to wear out or arc, the solid state circuitry provides a compact, reliable positioning switch for extended service life when used within the specified parameters.

### SPECIFICATIONS

#### Solid State Switch

##### Sinking (NPN)

Switching Logic .....	Normally Open
Switching Voltage .....	5 VDC to 30 VDC
Switching Current.....	100mA Max. @ 5 VDC
.....	200mA Max. @ 12 VDC
.....	200mA Max. @ 24 VDC
Current Consumption.....	10mA Max. @ 12 VDC
.....	20mA Max. @ 24 VDC
Ambient Temperature .....	14°F to 140°F
Indicator .....	Red LED
Plain End Lead Wire .....	39 in.
M8 Pigtail Connector.....	.6 in.
Enclosure Rating.....	IEC Standard IP66

##### Sourcing (PNP)

Switching Logic .....	Normally Open
Switching Voltage.....	5 VDC to 30 VDC
Switching Current.....	100mA Max. @ 12 VDC
.....	200mA Max. @ 24 VDC
Current Consumption .....	7mA Max. @ 12 VDC
.....	14mA Max. @ 24 VDC
Ambient Temperature.....	14°F to 140°F
Indicator.....	Green LED
Plain End Lead Wire.....	39 in.
M8 Pigtail Connector.....	.6 in.
Enclosure Rating.....	IEC Standard IP66

Wiring Diagram:

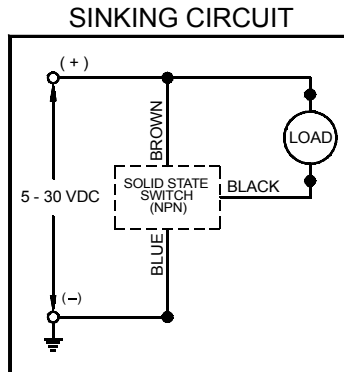

Wiring Diagram:

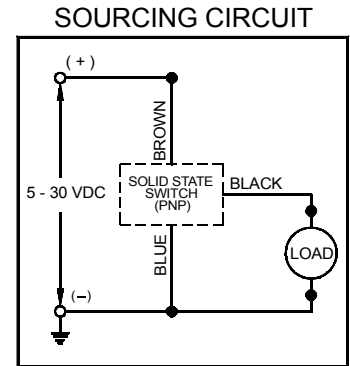

## SWITCH DIMENSIONAL DATA

Std. Lead Wires w/Bands

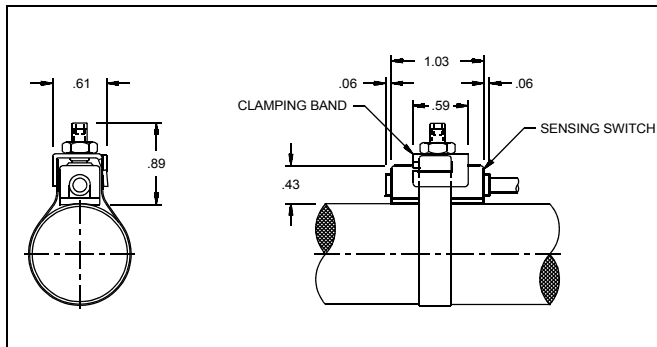

Pigtail Connection Type w/Bands

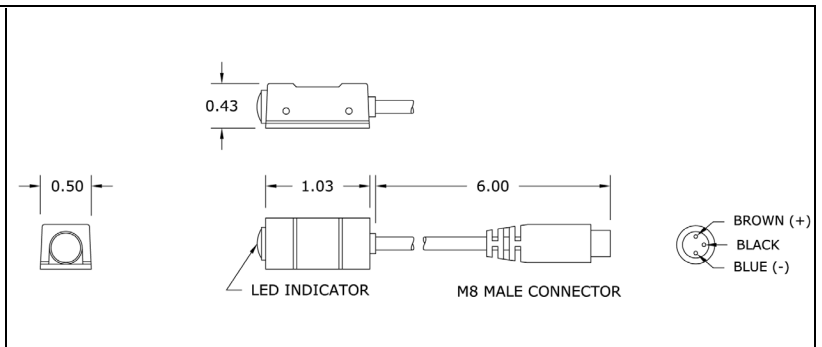

# SWITCH PART NUMBERS

## Reed Switches

Complete with band.

Bore		Std. Lead Wires - With Bands			Pigtail Connection Type - With Bands			Band Only
Stainless Steel Body	Aluminum Body	Non-LED 39"	LED 39"	LED 72"	LED Switch w/6" Pigtail	LED Pigtail Switch w/2M (78") Cable	LED Pigtail Switch w/5M (196") Cable	
9/16"	----	M16S	M16SL	M16SL-72	M16SL-PT	M16SL-PT-78	M16SL-PT-196	590-003-0
3/4"	----	M26S	M26SL	M26SL-72	M26SL-PT	M26SL-PT-78	M26SL-PT-196	290-008-0
1 1/16"	----	M36S	M36SL	M36SL-72	M36SL-PT	M36SL-PT-78	M36SL-PT-196	390-008-0
----	1 1/8"	M46	M46L	M46L-72	M46L-PT	M46L-PT-78	M46L-PT-196	490-008-0
1 1/4"	----	M56S	M56SL	M56SL-72	M56SL-PT	M56SL-PT-78	M56SL-PT-196	090-002-0
1 1/2"	----	M66S	M66SL	M66SL-72	M66SL-PT	M66SL-PT-78	M66SL-PT-196	690-015-0
----	1 1/2"	M66	M66L	M66L-72	M66L-PT	M66L-PT-78	M66L-PT-196	690-014-0
1 3/4"	----	M76S	M76SL	M76SL-72	M76SL-PT	M76SL-PT-78	M76SL-PT-196	190-006-0
2"	----	M86S	M86SL	M86SL-72	M86SL-PT	M86SL-PT-78	M86SL-PT-196	890-023-0
----	2"	M86	M86L	M86L-72	M86L-PT	M86L-PT-78	M86L-PT-196	890-011-0
----	2 1/2"	M96	M96L	M96L-72	M96L-PT	M96L-PT-78	M96L-PT-196	990-004-0
Switch & Cable (no band)		MS-6	MSL-6	MSL-S-72	MSL6-PT	MSL6-PT-78	MSL6-PT-196	
<b>Cables Only for Pigtail Switches</b>								
						2M (78")	PT-78	
						5M (196")	PT-196	

## Solid State Switches

Complete with band.

Bore		Std. Lead Wires w/ Bands		Pigtail Connection Type w/Bands						
Stainless Steel Body	Aluminum Body	Sinking (NPN)	Sourcing (PNP)	Switches w/6" Pigtail		Pigtail Switch w/2M (78") Cable		Pigtail Switch w/5M (196") Cable		Band Only
				Sinking (NPN)	Sourcing (PNP)	Sinking (NPN)	Sourcing (PNP)	Sinking (NPN)	Sourcing (PNP)	
9/16"	----	M16SH	M16SHP	M16SH-PT	M16SHP-PT	M16SH-PT-78	M16SHP-PT-78	M16SH-PT-196	M16SHP-PT-196	590-003-0
3/4"	----	M26SH	M26SHP	M26SH-PT	M26SHP-PT	M26SH-PT-78	M26SHP-PT-78	M26SH-PT-196	M26SHP-PT-196	290-008-0
1 1/16"	----	M36SH	M36SHP	M36SH-PT	M36SHP-PT	M36SH-PT-78	M36SHP-PT-78	M36SH-PT-196	M36SHP-PT-196	390-008-0
----	1 1/8"	M46H	M46HP	M46H-PT	M46HP-PT	M46H-PT-78	M46HP-PT-78	M46H-PT-196	M46HP-PT-196	490-008-0
1 1/4"	----	M56SH	M56SHP	M56SH-PT	M56SHP-PT	M56SH-PT-78	M56SHP-PT-78	M56SH-PT-196	M56SHP-PT-196	090-002-0
1 1/2"	----	M66SH	M66SHP	M66SH-PT	M66SHP-PT	M66SH-PT-78	M66SHP-PT-78	M66SH-PT-196	M66SHP-PT-196	690-015-0
----	1 1/2"	M66H	M66HP	M66H-PT	M66HP-PT	M66H-PT-78	M66HP-PT-78	M66H-PT-196	M66HP-PT-196	690-014-0
1 3/4"	----	M76SH	M76SHP	M76SH-PT	M76SHP-PT	M76SH-PT-78	M76SHP-PT-78	M76SH-PT-196	M76SHP-PT-196	190-006-0
2"	----	M86SH	M86SHP	M86SH-PT	M86SHP-PT	M86SH-PT-78	M86SHP-PT-78	M86SH-PT-196	M86SHP-PT-196	890-023-0
----	2"	M86H	M86HP	M86H-PT	M86HP-PT	M86H-PT-78	M86HP-PT-78	M86H-PT-196	M86HP-PT-196	890-011-0
----	2 1/2"	M96H	M96HP	M96H-PT	M96HP-PT	M96H-PT-78	M96HP-PT-78	M96H-PT-196	M96HP-PT-196	990-004-0
Switch & Cable (no band)		MSHL-6	MSHP-6	MSH6-PT	MSHP6-PT	MSH6-PT-78	MSHP6-PT-78	MSH6-PT-196	MSHP6-PT-196	
<b>Cables Only for Pigtail Switches</b>										
						2M (78")		PT-78		
						5M (196")		PT-196		

## MOUNTING ACCESSORIES: Dimensional Data

### Foot Bracket

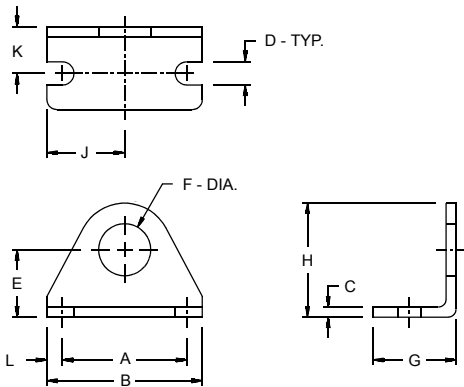

#### Stainless Body Series

Bore	Foot Bkt. No.	Dimension										
		A	B	C	D	E	F	G	H	J	K	L
9/16"	M11SD	1.00	1.37	.07	.18	.56	.43	.62	.93	.68	.31	.18
3/4" S.A.	M21SS	1.25	1.62	.10	.18	.68	.50	.75	1.09	.81	.43	.18
3/4"	M21	1.50	1.87	.12	.28	.81	.62	1.00	1.37	.93	.56	.18
1 1/16"	M21	1.50	1.87	.12	.28	.81	.62	1.00	1.37	.93	.56	.18
1 1/4"	M61S	1.87	2.50	.15	.28	1.00	.75	1.50	1.75	1.25	.75	.31
1 1/2"	M61S	1.87	2.50	.15	.28	1.00	.75	1.50	1.75	1.25	.75	.31
1 3/4"	M71S	2.25	3.00	.18	.34	1.25	1.03	1.50	2.12	1.50	.87	.37
2"	M81S	2.25	3.12	.25	.34	1.50	1.37	1.62	2.56	1.56	1.00	.43

Note: One mounting nut is provided with each foot bracket ordered.

#### Aluminum Body Series

Bore	Foot Bkt. No.	Dimension										
		A	B	C	D	E	F	G	H	J	K	L
1 1/8"	M41	1.50	1.87	.12	.28	.87	.75	1.06	1.50	.93	.59	.18
1 1/2"	M61	1.87	2.37	.21	.28	1.18	1.00	1.37	2.06	1.18	.78	.25
2"	M81	2.37	3.00	.25	.34	1.50	1.25	1.68	2.56	1.50	.96	.31
2 1/2"	M91	2.87	3.75	.25	.34	1.75	1.50	1.62	3.06	1.87	1.00	.43

Note: One mounting nut is provided with each foot bracket ordered.

### Mounting Nut

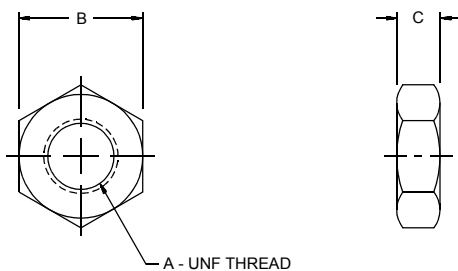

Bore	Mtg. Nut No.		Dimension		
	SS Body	AL Body	A	B	C
9/16"	M15SD	--	7/16-20	.68	.25
3/4" S.A.	M25SS	--	1/2-20	.75	.31
3/4"	M25	--	5/8-18	.93	.37
1 1/16"	M25	--	5/8-18	.93	.37
1 1/8"	--	M45	3/4-16	1.12	.42
1 1/4"	M45	--	3/4-16	1.12	.42
1 1/2"	M45	--	3/4-16	1.12	.42
1 1/2"	--	M65	1-14	1.50	.54
1 3/4"	M65	--	1-14	1.50	.54
2"	M85	--	1 1/4-12	1.87	.54
2"	--	M85	1 1/4-12	1.87	.54
2 1/2"	--	M95	1 3/8-12	1.87	.50

### Flange Mount

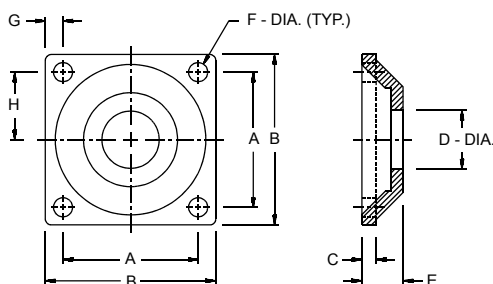

#### Aluminum Body Series

Bore	Flange No.	Dimension							
		A	B	C	D	E	F	G	H
1 1/8"	M42	2.00	2.50	.25	.75	.62	.28	.25	1.00
1 1/2"	M62	2.50	3.25	.31	1.00	.75	.28	.37	1.25
2"	M82	2.87	3.62	.31	1.25	.87	.28	.37	1.43

Note: One mounting nut is provided with each flange ordered.

## MOUNTING ACCESSORIES: Dimensional Data (Continued)

### Rod Clevis

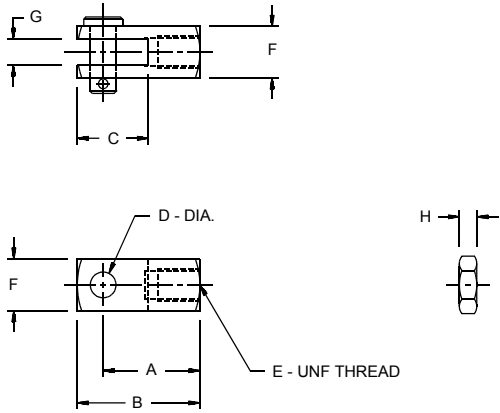

Bore	Rod Clevis No.		Dimension								
	SS Body	AL Body	A	B	C	D	E	F	G	H	
9/16"	M14S	--	.75	.93	.56	.18	10-32	.37	.18	.12	
3/4"	M24S	--	.93	1.18	.68	.25	1/4-28	.50	.25	.15	
1 1/16"	M24	--	.93	1.18	.68	.25	5/16-24	.50	.25	.18	
1 1/8"	--	M44	1.12	1.37	.68	.25	3/8-24	.56	.25	.21	
1 1/4"	M64S	--	1.31	1.68	.93	.37	7/16-20	.75	.37	.25	
1 1/2"	M64S	--	1.31	1.68	.93	.37	7/16-20	.75	.37	.25	
1 1/2"	--	M64	1.43	1.81	.93	.37	1/2-20	.75	.37	.31	
1 3/4"	M94	--	1.31	1.68	.93	.37	1/2-20	.75	.37	.37	
2"	M94	--	1.31	1.68	.93	.37	1/2-20	.75	.37	.37	
2"	--	M84	1.87	2.31	1.31	.43	5/8-18	.87	.43	.37	
2 1/2"	--	M94	1.31	1.68	.93	.37	1/2-20	.75	.37	.37	

Note: Rod nut and pin provided with each rod clevis ordered.

### Pivot/Trunnion Bracket

#### Stainless Body Series

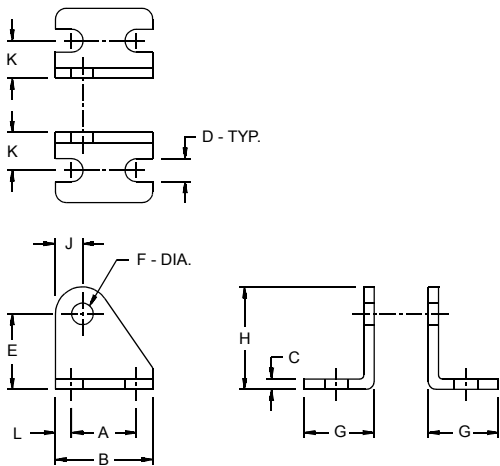

#### Pivot Bracket

Bore	Pivot Bkt. No.	Dimension										
		A	B	C	D	E	F	G	H	J	K	L
9/16"	M13S	.50	.75	.06	.18	.56	.15	.50	.77	.20	.28	.12
3/4"	M23S	.75	1.12	.12	.26	.87	.25	.81	1.18	.31	.43	.18
1 1/16"	M23S	.75	1.12	.12	.26	.87	.25	.81	1.18	.31	.43	.18
1 1/4"	M23S	.75	1.12	.12	.26	.87	.25	.81	1.18	.31	.43	.18
1 1/2"	M63S	1.00	1.50	.12	.26	1.37	.37	1.00	1.75	.37	.62	.25
1 3/4"	M73SP	1.00	1.50	.25	.34	1.37	.37	1.12	1.75	.37	.68	.25
2"	M93	1.00	1.50	.25	.34	1.37	.37	1.12	1.75	.37	.68	.25
2 1/2"	M93	1.00	1.50	.25	.34	1.37	.37	1.12	1.75	.37	.68	.25

Notes: • Add the letter "P" to Bracket No. to include Pivot Pin for use with cylinders having (-2) Pivot Bushing Option (ex. M23SP).  
• Pivot Pin always included with M73SP and M93 Pivot Bracket.

#### Trunnion Bracket

Bore	Trunnion Bkt. No.	Dimension										
		A	B	C	D	E	F	G	H	J	K	L
3/4"	M37S	1.00	1.50	.25	.34	1.37	.50	1.12	1.75	.37	.68	.25
1 1/16"	M37S	1.00	1.50	.25	.34	1.37	.50	1.12	1.75	.37	.68	.25
1 1/2"	M37S	1.00	1.50	.25	.34	1.37	.50	1.12	1.75	.37	.68	.25

#### Aluminum Body Series

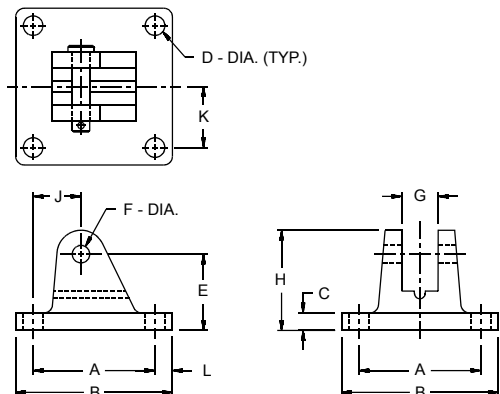

#### Pivot Bracket

Bore	Pivot Bkt. No.	Dimension										
		A	B	C	D	E	F	G	H	J	K	L
1 1/8"	M43	1.75	2.25	.25	.28	1.09	.25	.50	1.43	.68	.87	.25
1 1/2"	M63	2.25	3.00	.31	.28	1.62	.31	.75	2.12	.87	1.12	.37
2"	M83	2.25	3.00	.31	.28	1.62	.31	.75	2.12	.87	1.12	.37
2 1/2"	M93	Listed in Stainless Body Series above.										

Note: Pivot pin included with each Aluminum Body Series pivot bracket ordered.





---

## American Cylinder Co., Inc.

---

**American Cylinder Co., Inc.**  
Peotone, Illinois 60468-9116  
708/258-3935  
FAX 708/258-3980

### ON THE INTERNET

<http://www.americancylinder.com>

<http://www.ameristore.biz>

E-MAIL: [amcyl@americancylinder.com](mailto:amcyl@americancylinder.com)

## Warranty

American Cylinder Co., Inc. warrants its products to be free from defects in material and workmanship under normal wear and service for a period of 3 years from date of shipment of the order. American Cylinder Company shall have no liability under this warranty if: 1) The product is used other than in accordance with specifications. 2) The product is subjected to abuse, negligence, accident, misapplication, or unintended use. 3) The product is manufactured to buyer's specifications.

Manufacturer's liability shall be limited to allowance of credit or replacement of defective product. American Cylinder Company shall not be liable or responsible for injuries or damages to persons or property arising out of the use or operation of American Cylinder products.

THIS WARRANTY IS EXPRESSLY IN LIEU OF ALL OTHER WARRANTIES, EXPRESSED OR IMPLIED, INCLUDING ANY IMPLIED WARRANTY OF MERCHANTABILITY OR FITNESS FOR A PARTICULAR PURPOSE, LIABILITY FOR LOST PROFIT OR FOR INDIRECT, INCIDENTAL, CONSEQUENTIAL OR COMMERCIAL LOSSES, AND OF ALL OTHER OBLIGATIONS OR LIABILITIES.

These conditions subject to change without notice.